



DTG2A3

Teknik Saluran Transmisi

By : Dwi Andi Nurmantris



1. KONSEP PANTULAN DALAM SALURAN TRANSMISI

Where Are We?

1. PENDAHULUAN

- Perkenalan dan sosialisasi SAP&syllabus
- Review materi teori elektromagnetik

2. TEORI SALURAN TRANSMISI

- Definisi Saluran transmisi
- Konsep dan contoh Saluran transmisi
- Model Saluran transmisi
- Pengenalan parameter-parameter Saluran transmisi
- Persamaan Umum Saluran Transmisi)
- Konsep Bandwidth Saluran

3. KONDISI DAN TIPE SALTRAN

- Saluran lossless
- Saluran distortionless
- Saluran lossy
- Saluran-saluran istimewa

4. KONSEP PANTULAN PADA SALURAN

- SWR & VSWR
- Koefisien pantul
- Daya yang diserap beban
- Praktikum Karakteristik Saluran Transmisi (Impedansi Input, VSWR, Koefisien Pantul, Pola Gelombang berdiri)

5. Kasus khusus Impedansi sumber dan Beban

- Beban OC dan SC
- Kasus Khusus lainnya

6. MACAM-MACAM SALTRAN

- Saluran Transmisi Dua Kawat
- Coaxial Cable
- MicrostripLine
- StripLine
- Waveguide
- Coplanar Waveguide

7. MATCHING IMPEDANCE

- Definisi matching impedance
- Tujuan matching impedance
- Teknik Penyepadan saluran transmisi dengan Trafo $\lambda/4$ Open Circuit/Short Circuit)
- Teknik Penyepadan saluran transmisi dengan stub tunggal (Paralel/Seri dan Open Circuit/Short Circuit)
- Teknik Penyepadan saluran transmisi dengan stub Ganda (Paralel/Seri dan Open Circuit/Short Circuit)
- Praktikum Matching Impedansi menggunakan Stub
- Perhitungan matching impedance menggunakan penyepadan rangkaian R, L, C

8. SMITCHCHART

- Pengenalan Smith Chart
- Tools pendukung
- Cara menggunakan Smith Chart
- Contoh penggunaan ($\lambda/4$ (transformator), Stub tunggal, stub ganda)
- Praktikum matching Impedansi Saluran Menggunakan Smith Chart



Pre-Test



1. Apakah penyebab pantulan dalam saluran transmisi?
2. Apa pengaruh pantulan dalam saluran transmisi?
3. Tuliskan persamaan gelombang datang dan pantul dalam saluran Lossy dan lossless
4. Apa yang dimaksud dengan koefisien pantul? tuliskan persamaannya?
5. Apa yang dimaksud SWR dan VSWR? Tuliskan persamaan VSWR?
6. Apakah nilai koefisien pantul di sepanjang saluran selalu sama untuk saluran lossy dan lossless?
7. Apakah nilai VSWR di sepanjang saluran selalu sama untuk saluran lossy dan lossless?
8. Apa yang dimaksud dengan return Loss?
9. Apa hubungan koefisien pantul, VSWR, dan RL?
10. Berapakah nilai koefisien pantul, VSWR, dan return loss untuk kondisi saluran berikut? a) infinite length saluran b) saluran dengan $Z_L=Z_0$ c) saluran dengan terminasi OC d) saluran dengan terminasi SC

Content



1. Pendahuluan
2. Koefisien Pantul
3. VSWR
4. Return Loss
5. Mismatch Loss
6. Daya kirim, daya pantul dan daya yang diserap

Pendahuluan



- ❑ Pantulan dalam saluran transmisi terjadi jika **sebagian atau seluruh** gelombang yang dikirim/merambat dalam saluran dipantulkan kembali ke arah sumber dari gelombang tersebut.
- ❑ Ada dua sebab utama gelombang dalam saluran transmisi mengalami pantulan yaitu :
 - a. Karakteristik saluran transmisi sepanjang titik tidak seragam (tidak uniform) → adanya perbedaan konstanta primer saluran di sepanjang saluran
 - b. Adanya *impedance mismatch* antara saluran dengan komponen yang terhubung dengan saluran tersebut (**Fokus kita**)
- ❑ Ada empat besaran yang saling berhubungan yang menjelaskan adanya fenomena pantulan gelombang dan efektifitas penransmisian daya dari suatu saluran transmisi ke beban :
 1. Reflection coefficient
 2. VSWR
 3. Mismatch Loss
 4. Return Loss

Pendahuluan



- ❑ Akibat dari pantulan pada saluran transmisi adalah :
 - a. Gelombang yang kembali dan sampai ke perangkat generator bisa merusak/membakar komponen-komponen di dalamnya
 - b. Daya yang di kirim akan berkurang karena sebagian hilang karena dipantulkan
- ❑ ...

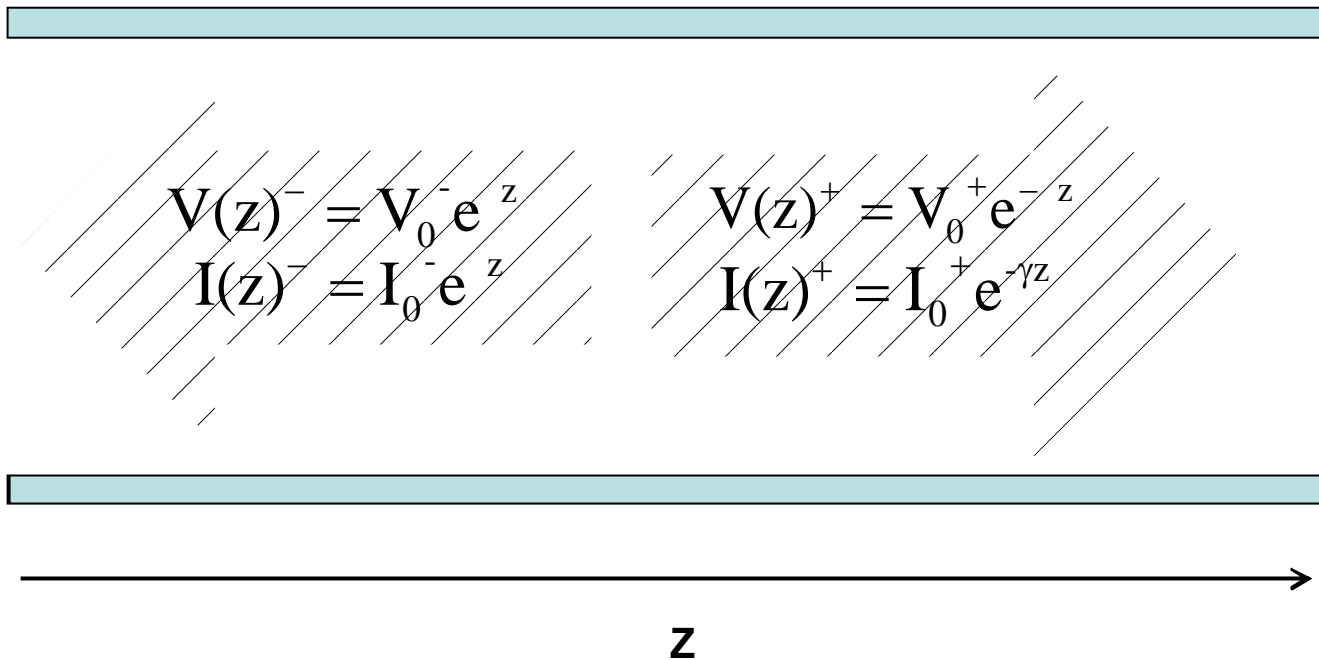

Reflection Coefficient



- Adalah besaran yang menyatakan perbandingan *gelombang pantul* terhadap *gelombang datang*

- **Koefisien pantul tegangan**

$$\Gamma_v(z) = \frac{V^-(z)}{V^+(z)} \quad 0 \leq |\Gamma_v(z)| \leq 1$$

- **Koefisien pantul arus**

$$\Gamma_i(z) = \frac{I^-(z)}{I^+(z)} \quad 0 \leq |\Gamma_i(z)| \leq 1$$

$$\Gamma_i(z) = \frac{I^-(z)}{I^+(z)} = \frac{-V^-(z)/Z_0}{V^+(z)/Z_0} = \frac{-V^-(z)}{V^+(z)} = -\Gamma_v(z)$$

- Magnitude koefisien pantul arus = magnitude koefisien pantul tegangan
- Beda fasa antara koefisien pantul tegangan dan koefisien pantul arus adalah 180°

Reflection Coefficient



Penurunan Koefisien Pantul

$$\Gamma_v(z) = \frac{V^-(z)}{V^+(z)} = \frac{V_0^- e^{+z}}{V_0^+ e^{-z}} = \frac{V_0^-}{V_0^+} e^{+2z}$$

□ Pada $Z=0$, maka:

$$\Gamma_v(z=0) = \frac{V^-(z=0)}{V^+(z=0)} = \frac{V_0^-}{V_0^+} e^{+2 \cdot 0} = \frac{V_0^-}{V_0^+} = \Gamma_0$$

Sehingga:

$$\Gamma_v(z) = \frac{V_0^-}{V_0^+} e^{+2z} = \Gamma_0 e^{+2z} = \Gamma_0 e^{+2(\alpha + j\beta)z} = \Gamma_0 e^{+2\alpha z} e^{+j2\beta z}$$

Magnitude

$$|\Gamma_v(z)| = \Gamma_0 e^{+2\alpha z}$$

Phase

$$\phi_\Gamma = 2\beta z$$

Reflection Coefficient

- Jika saluran transmisinya **Lossless** ($\alpha = 0$)

$$\Gamma_v(z) = \Gamma_0 e^{+j2\beta z}$$

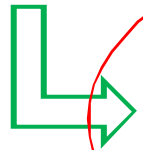

$$|\Gamma_v(z)| = \Gamma_0$$

$$\phi_\Gamma = 2\beta z$$

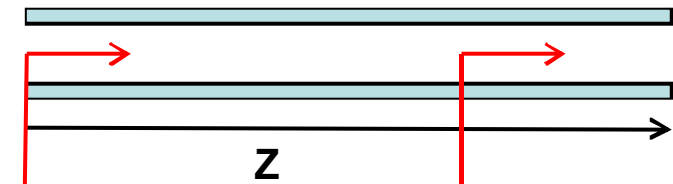

$$\Gamma_v(z=0) = \Gamma_0$$

$$\Gamma_v(z) = \Gamma_0 e^{j2\beta z}$$

Hubungan Koefisien Pantul dengan Impedansi beban dan impedansi saluran

$$\Gamma_v(z) = \frac{V^-(z)}{V^+(z)} \Rightarrow V^-(z) = \Gamma_v(z)V^+(z)$$

$$\left\{ \begin{array}{l} V(z) = V^+(z) + V^-(z) = V^+(z) + V^+(z)\Gamma_v(z) \\ \quad = V^+(z)(1 + \Gamma_v(z)) \\ I(z) = I^+(z) + I^-(z) = \frac{V^+(z)}{Z_0} - \frac{V^-(z)}{Z_0} \\ \quad = \frac{V^+(z)}{Z_0} - \frac{\Gamma_v(z)V^+(z)}{Z_0} = \frac{V^+(z)(1 - \Gamma_v(z))}{Z_0} \end{array} \right.$$

Reflection Coefficient



$$Z(z) = \frac{V(z)}{I(z)} = \frac{V^+(z)(1+\Gamma_v(z))}{\frac{V^+(z)(1-\Gamma_v(z))}{Z_0}} \Rightarrow Z(z) = Z_0 \frac{(1+\Gamma_v(z))}{(1-\Gamma_v(z))}$$

$$Z(z) - Z(z)\Gamma_v(z) = Z_0 + Z_0\Gamma_v(z)$$

$$\begin{aligned} Z(z) - Z_0 &= Z_0\Gamma_v(z) + Z(z)\Gamma_v(z) \\ &= (Z(z) + Z_0)\Gamma_v(z) \end{aligned}$$

$$\Gamma_v(z) = \frac{Z(z) - Z_0}{Z(z) + Z_0}$$

Sehingga

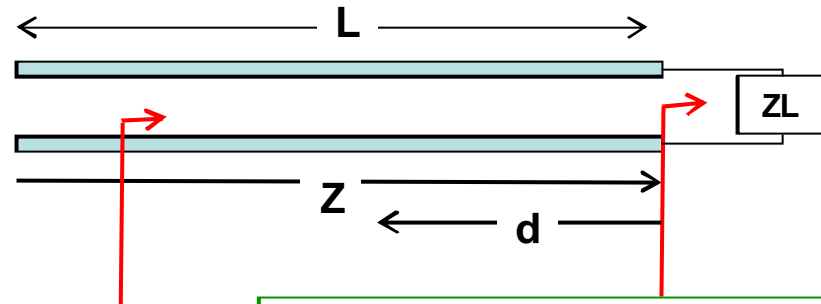

$$\begin{aligned} \Gamma_v(d) &= \left(\frac{Z_L - Z_0}{Z_L + Z_0} \right) e^{-2\alpha d} e^{-j2\beta d} \\ &= \left(\frac{Z_L - Z_0}{Z_L + Z_0} \right) e^{-j2\beta d} \Rightarrow \text{Lossless} \end{aligned}$$

$$\Gamma_v(z=L) = \Gamma_v(d=0) = \frac{Z_L - Z_0}{Z_L + Z_0}$$

Reflection Coefficient



Jadi Perlu
Dipahami!!!

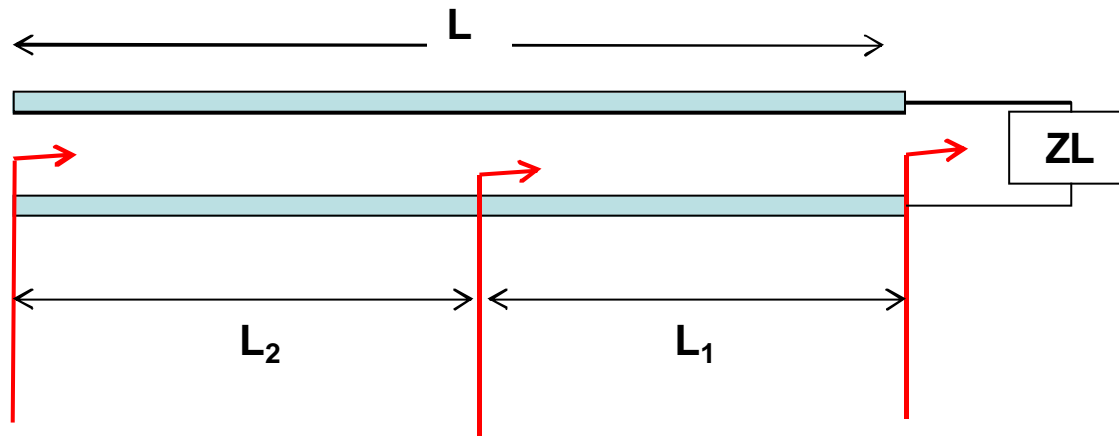

$$\Gamma_3 = \Gamma_2 e^{-2\alpha L_2} e^{-j2\beta L_2}$$

$$\Gamma_2$$

$$\Gamma_1 = \Gamma_2 e^{+2\alpha L_1} e^{+j2\beta L_1}$$

Gelombang Berdiri dan VSWR

- ❑ Gelombang berdiri terjadi jika dua buah gelombang yang arahnya saling berlawanan, bersuperposisi
- ❑ Gelombang datang pada saluran transmisi yang bersuperposisi dengan gelombang yang dipantulkan bisa membentuk gelombang berdiri .

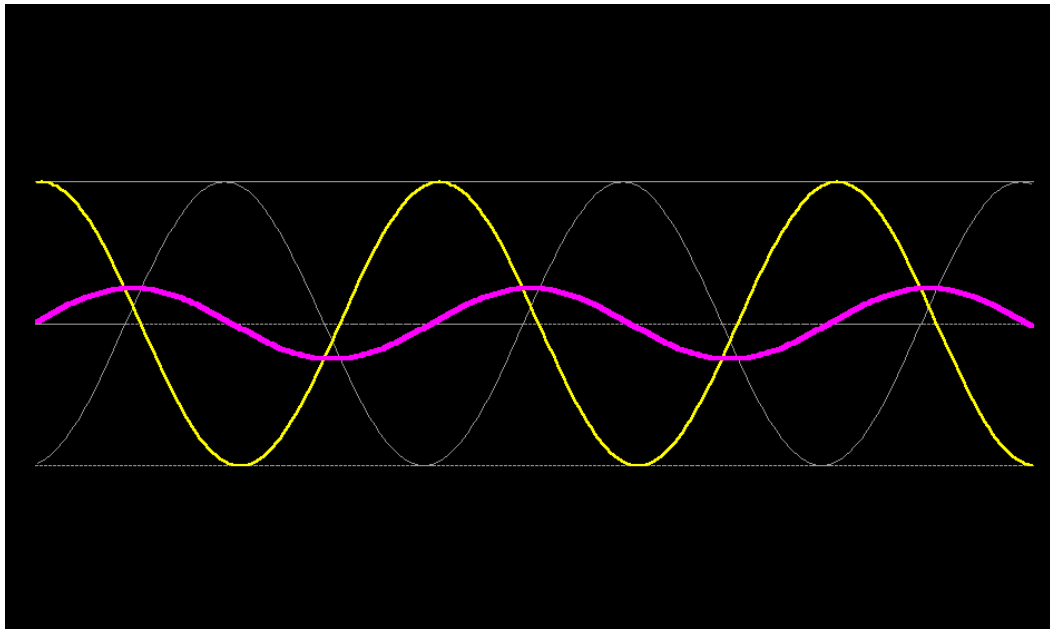

- ❑ VSWR (Voltage Standing Wave Ratio) → adalah perbandingan magnitude tegangan maksimum dengan magnitude tegangan minimum pada gelombang berdiri pada suatu titik di saluran transmisi

$$VSWR(z) = \frac{|V(z)|_{\max}}{|V(z)|_{\min}}$$

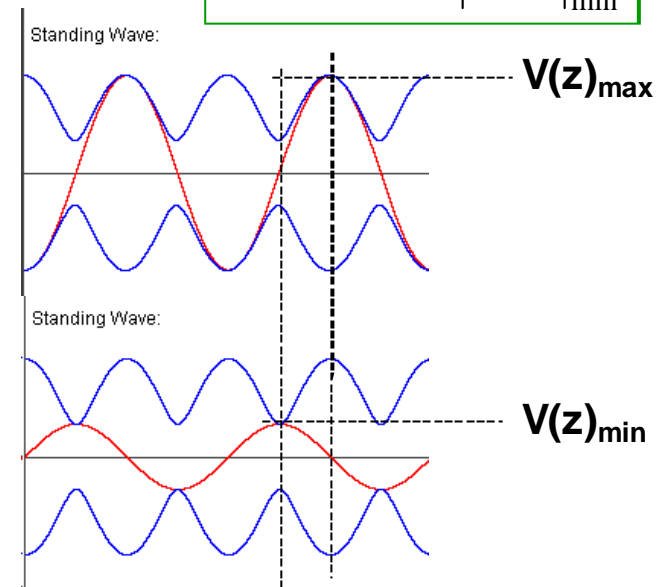

Gelombang Berdiri dan VSWR



Penurunan VSWR

$$V(z) = V^+(z) + V^-(z) = V^+(z) + V^+(z)\Gamma_v(z)$$

Tegangan maksimum $V(z)_{\max}$ terjadi apabila disuatu titik disaluran, teg datang dan teg pantul **sefasa**

$$V(z)_{\max} = V^+(z) + V^-(z) = V^+(z) + V^+(z)\Gamma_v(z)$$

Tegangan minimum $V(z)_{\min}$ terjadi apabila disuatu titik disaluran, teg datang dan teg pantul berbeda fasa 180°

Sehingga:

$$V(z)_{\min} = V^+(z) - V^-(z) = V^+(z) - V^+(z)\Gamma_v(z)$$

$$VSWR(z) = \frac{|V(z)|_{\max}}{|V(z)|_{\min}} = \frac{|V^+(z) + V^+(z)\Gamma_v(z)|}{|V^+(z) - V^+(z)\Gamma_v(z)|} = \frac{(1 + |\Gamma_v(z)|)|V^+(z)|}{(1 - |\Gamma_v(z)|)|V^+(z)|} = \frac{1 + |\Gamma_v(z)|}{1 - |\Gamma_v(z)|}$$

$$VSWR(z) = \frac{1 + |\Gamma_v(z)|}{1 - |\Gamma_v(z)|} = \frac{1 + |\Gamma_0 e^{+2\alpha z} e^{+j2\beta z}|}{1 - |\Gamma_0 e^{+2\alpha z} e^{+j2\beta z}|} = \frac{1 + |\Gamma_0 e^{+2\alpha z}|}{1 - |\Gamma_0 e^{+2\alpha z}|}$$

Gelombang Berdiri dan VSWR



Penurunan VSWR

Jika saluran lossless

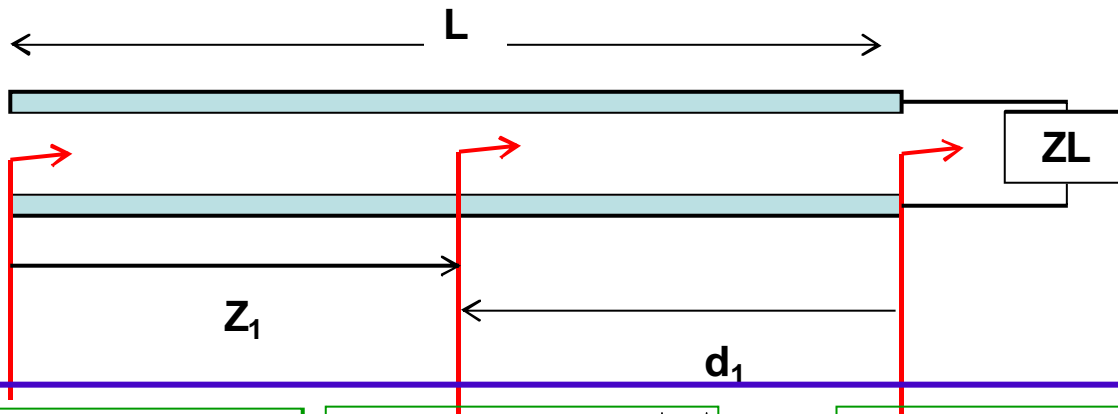

$VSWR(z = 0) = \frac{1 + \Gamma_0 }{1 - \Gamma_0 }$	$VSWR(z = z_1) = \frac{1 + \Gamma_0 }{1 - \Gamma_0 }$	$VSWR(z = L) = \frac{1 + \Gamma_0 }{1 - \Gamma_0 }$
	$VSWR(d = d_1) = \frac{1 + Z_L - Z_0 }{1 - Z_L + Z_0 }$	$VSWR(d = 0) = \frac{1 + Z_L - Z_0 }{1 - Z_L + Z_0 }$

Apa Kesimpulannya???

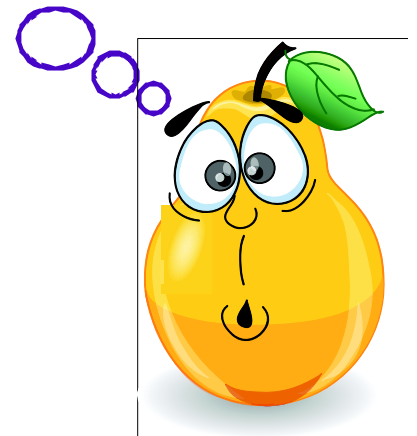

Contoh Soal



1.

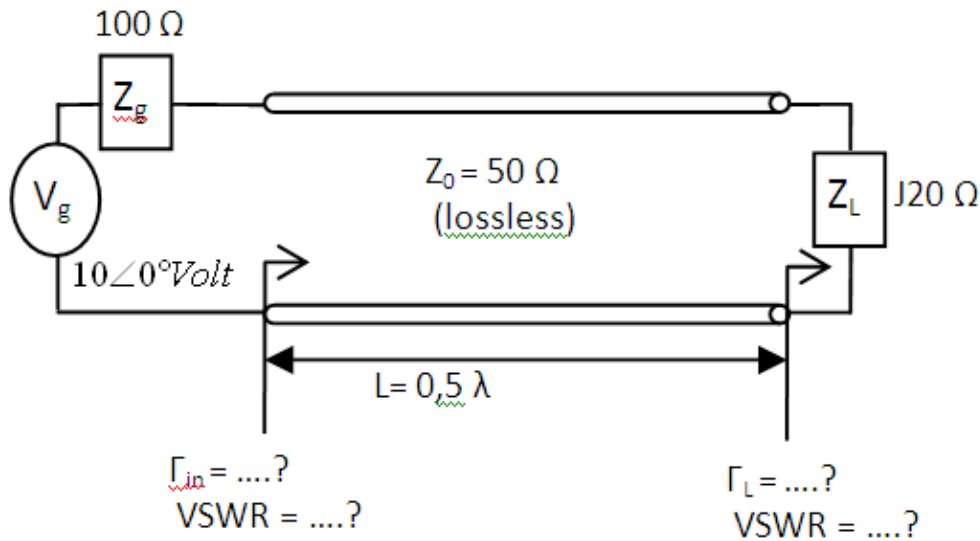

2.

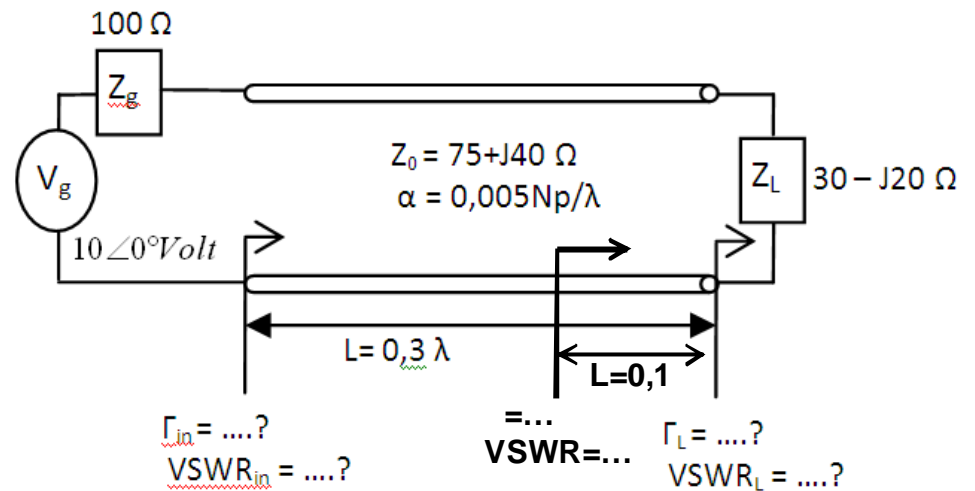

Power Flow and Return Loss

- Power Flow dalam saluran transmisi yang lossless bisa dilihat dari gambar dibawah ini :

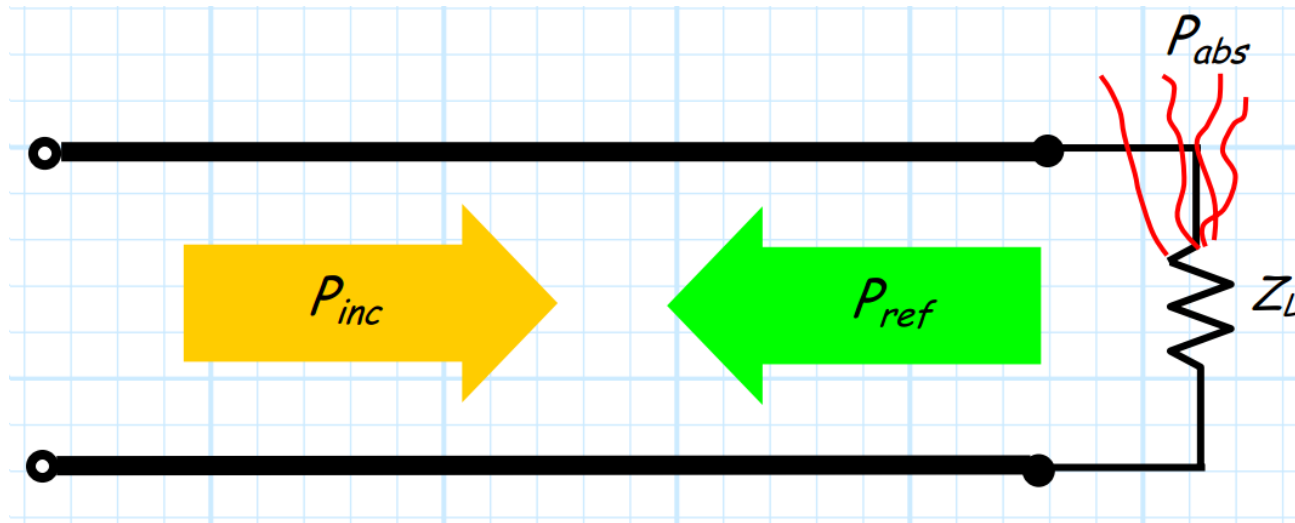

$$P_{abs} = P_{inc} - P_{ref}$$

Power Flow dan Return Loss



Penurunan Return Loss

- Adalah besaran yang menyatakan perbandingan antara daya yang dipantulkan dengan daya yang datang

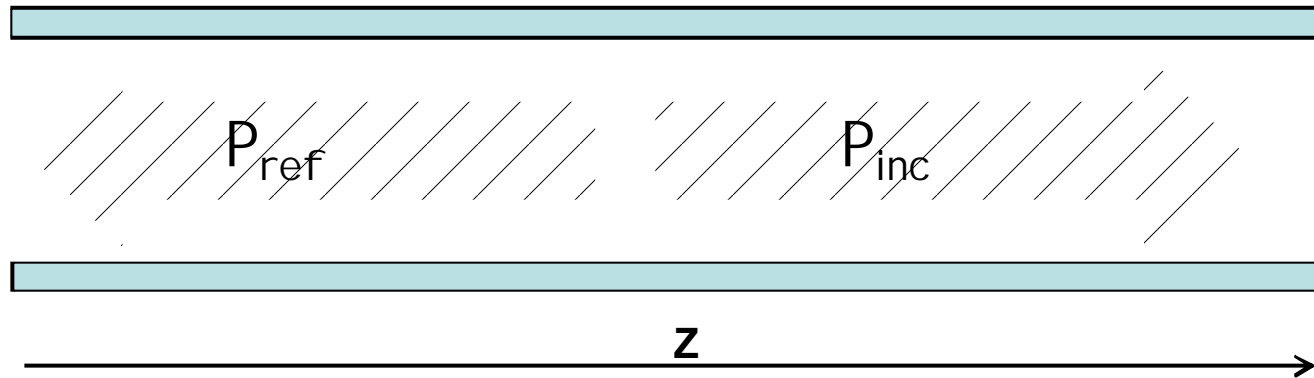

$$RL(z) = \frac{P_{\text{ref}}}{P_{\text{inc}}} = \frac{\frac{(V^-(z))^2}{R}}{\frac{(V^+(z))^2}{R}} = \left(\frac{V^-(z)}{V^+(z)} \right)^2 = |\Gamma_v(z)|^2$$

$$RL(z) = 10 \log \left(\frac{P_{\text{ref}}}{P_{\text{inc}}} \right) = 10 \log |\Gamma_v(z)|^2 = 20 \log |\Gamma_v(z)|$$

Mismatch Loss



Penurunan Mismatch Loss

- Adalah besaran yang menyatakan perbandingan antara daya yang diteruskan dengan daya yang datang

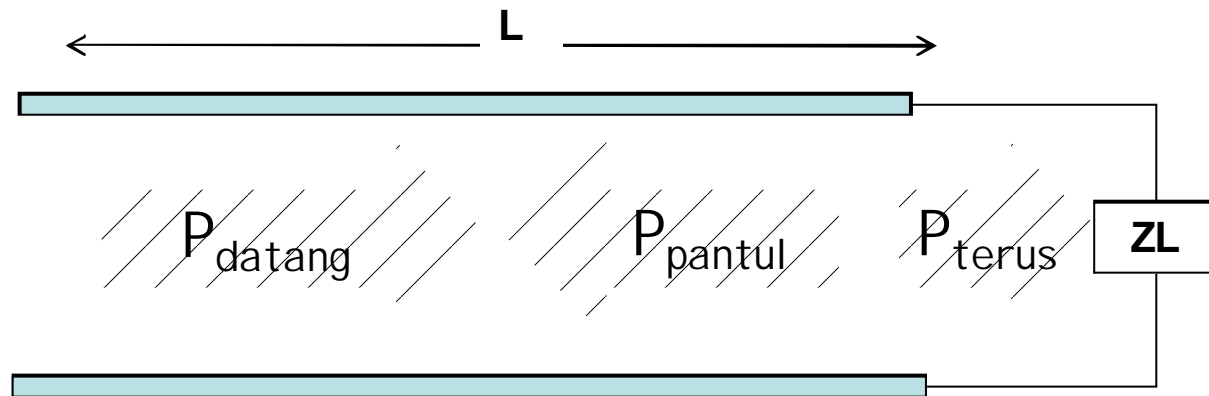

$$\begin{aligned} \text{Mismatch Loss}(z) &= \frac{P_{\text{terus}}}{P_{\text{datang}}} = \frac{P_{\text{datang}} - P_{\text{pantul}}}{P_{\text{datang}}} = \frac{P_{\text{datang}} - P_{\text{datang}} |\Gamma_v(z)|^2}{P_{\text{datang}}} = \frac{P_{\text{datang}} (1 - |\Gamma_v(z)|^2)}{P_{\text{datang}}} \\ &= 1 - |\Gamma_v(z)|^2 \end{aligned}$$

$$\text{Mismatch Loss}(z) = 10 \log(1 - |\Gamma_v(z)|^2)$$

Latihan Soal



VSWR	Γ	RL (dB)	Missmatch Loss (dB)
1
....	0,01
....	-30
....	0,1
1,5
....	-10
2
2,5

Delivered Power

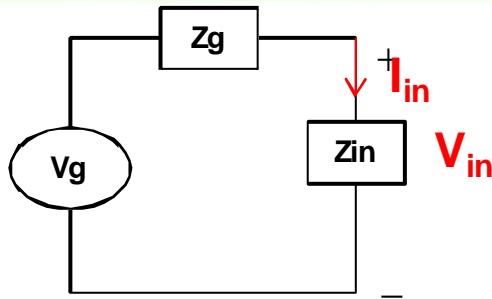

$$V_{in}(t) = V_m \cos(\omega t + \theta_v)$$

$$I_{in}(t) = I_m \cos(\omega t + \theta_i)$$

Daya sesaat

$$P_{in}(t) = V_{in}(t) \times I_{in}(t)$$

$$= V_m \cos(\omega t + \theta_v) \times I_m \cos(\omega t + \theta_i)$$

$$= \frac{1}{2} V_m I_m \cos(\theta_v - \theta_i) + \frac{1}{2} V_m I_m \cos(2\omega t + \theta_v + \theta_i)$$

$$Z_g = R_g + jX_g$$

$$Z_{in} = R_{in} + jX_{in}$$

$$V_{in(R)} = \frac{R_{in}}{R_{in} + jX_{in}} V_{in}$$

Daya Rata-rata

$$P_{in}(av) = \frac{1}{T} \int_0^T P_{in}(t) dt$$

$$= \frac{1}{2} V_m I_m \cos(\theta_v - \theta_i) = \frac{1}{2} \operatorname{Re}\{V_{in} I_{in}^*\}$$

$$P_{in}(av) = \frac{1}{2} \frac{|V_{in(R)}|^2}{R_{in}}$$

$$P_{in}(av) = \frac{1}{2} |I_{in}|^2 R_{in}$$

$$P_{in}(av) = \frac{1}{2} |V_{in(R)}| |I_{in}|$$

Delivered Power



Contoh

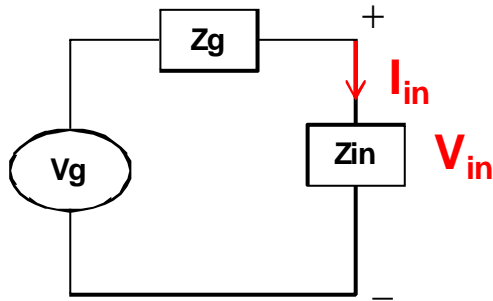

$$V_{in} = 120 \angle 0^\circ \text{ volt}$$

$$Z_{in} = 30 - j70 \Omega$$

$$P_{in} (av) = \dots\dots ????$$

Delivered Power



TRANSFER DAYA MAKSIMUM

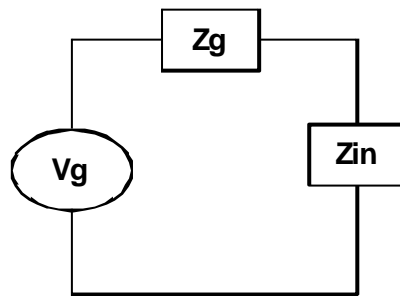
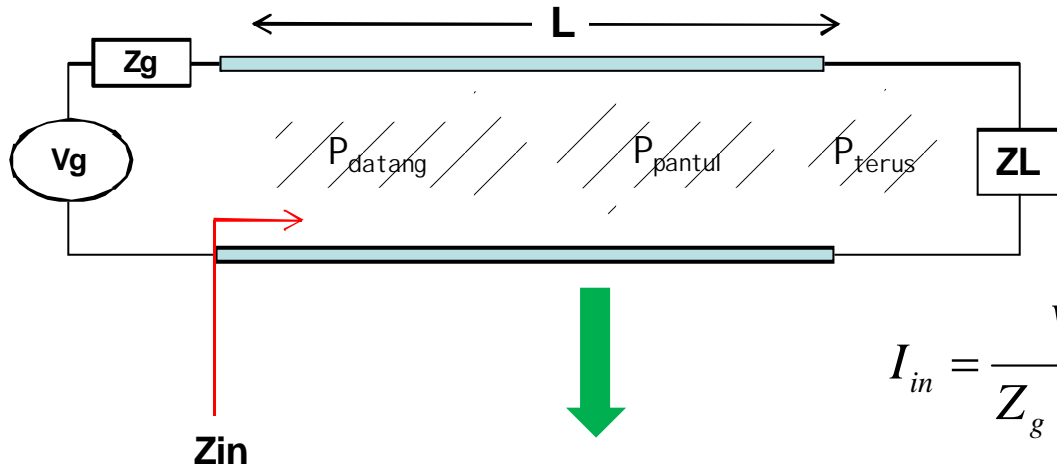

Akan maksimum jika

$$R_{in} = R_g$$

$$X_{in} = -X_g$$

$$I_{in} = \frac{V_g}{Z_g + Z_{in}} = \frac{V_g}{(R_g + jX_g) + (R_{in} + jX_{in})}$$

$$P_{in} = \frac{1}{2} |I_{in}|^2 R_{in} = \frac{1}{2} \left| \frac{V_g}{Z_g + Z_{in}} \right|^2 R_{in}$$

$$= \frac{1}{2} \left| \frac{V_g}{(R_g + jX_g) + (R_{in} + jX_{in})} \right|^2 R_{in}$$

$$= \frac{1}{2} \frac{V_g^2}{(R_g + R_{in})^2 + (X_g + X_{in})^2} R_{in}$$

$$Z_{in} = Z_g^*$$

Delivered Power

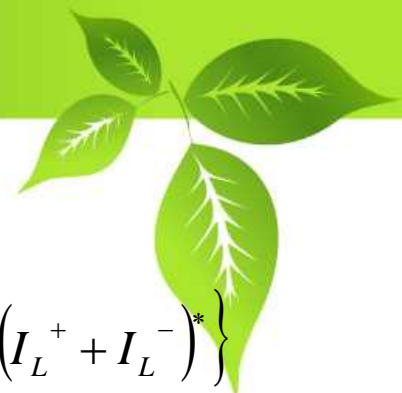

PADA SALURAN LOSSLESS

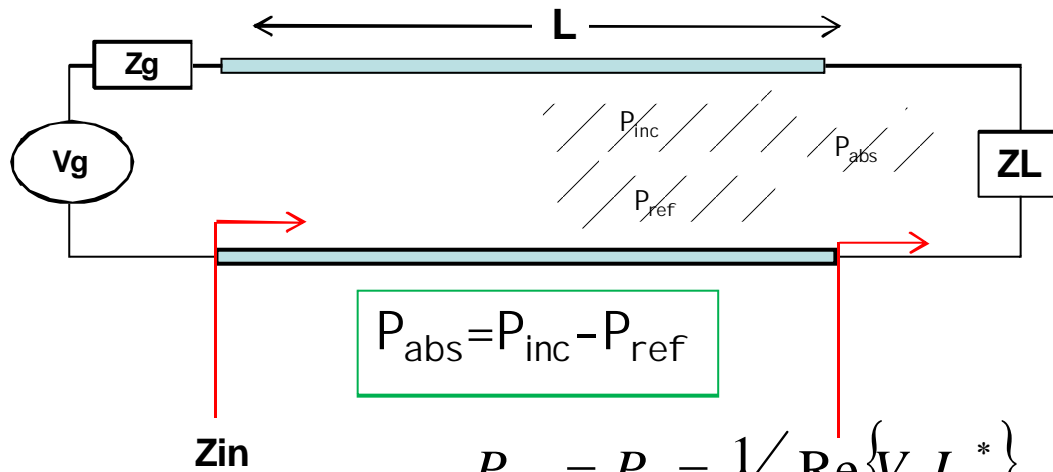

$$\begin{aligned}
 P_{abs} &= \frac{1}{2} \operatorname{Re}\{V_L I_L^*\} \\
 &= \frac{1}{2} \operatorname{Re}\{(V_L^+ + V_L^-)(I_L^+ + I_L^-)^*\} \\
 &= \frac{1}{2} \operatorname{Re}\{(V_L^+ + V_L^+ \Gamma_L)(I_L^+ - I_L^+ \Gamma_L)^*\} \\
 &= \frac{1}{2} \operatorname{Re}\left\{(V_L^+ + V_L^+ \Gamma_L) \left(\frac{V_L^+}{Z_0} - \frac{V_L^+}{Z_0} \Gamma_L\right)^*\right\} \\
 &= \frac{1}{2Z_0} \operatorname{Re}\{(V_L^+ + V_L^+ \Gamma_L)(V_L^+ - V_L^+ \Gamma_L)^*\} \\
 &= \dots\dots\dots
 \end{aligned}$$

$$\begin{aligned}
 P_{in} &= \frac{1}{2} \operatorname{Re}\{V_{in} I_{in}^*\} \\
 P_{abs} &= P_L = \frac{1}{2} \operatorname{Re}\{V_L I_L^*\} \\
 &= P_{in} \text{ (Karena Lossless)}
 \end{aligned}$$

$$\begin{aligned}
 V_L &= V_L^+ + V_L^- = V_L^+ + V_L^+ \Gamma_L \\
 &= V_L^+ (1 + \Gamma_L) \\
 V_L^+ &= \frac{V_L}{1 + \Gamma_L}
 \end{aligned}$$

$$P_{abs} = \frac{|V_L^+|^2}{2Z_0} (1 - |\Gamma_L|^2) = \frac{|V_L^+|^2}{2Z_0} - \frac{|V_L^+ \Gamma_L|^2}{2Z_0}$$

$$\begin{aligned}
 P_{inc} &\leftarrow \frac{|V_L^+|^2}{2Z_0} \\
 P_{ref} &\rightarrow \frac{|V_L^-|^2}{2Z_0}
 \end{aligned}$$

Delivered Power



Contoh-contoh Kasus

Hitung P_{in} dan P_L???

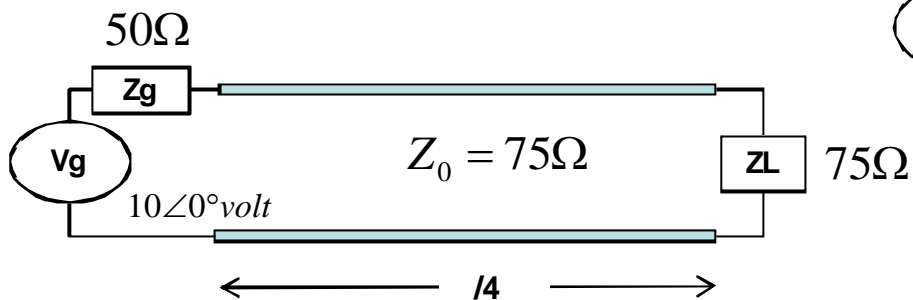
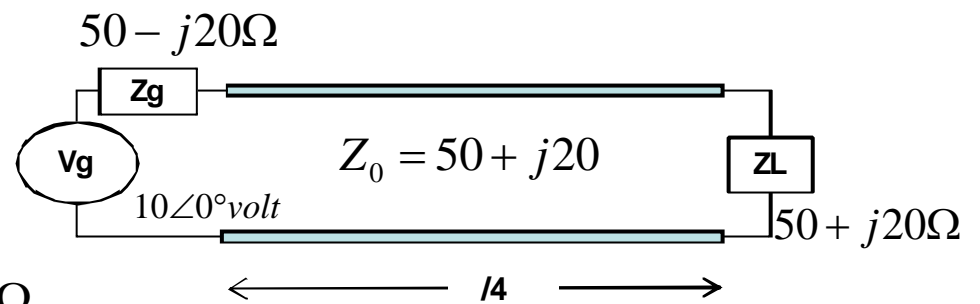
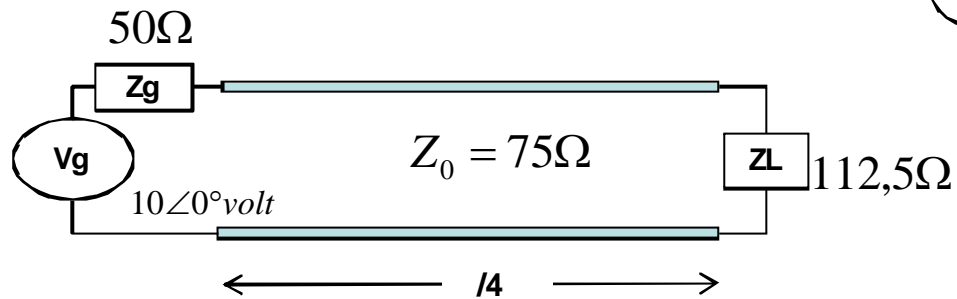
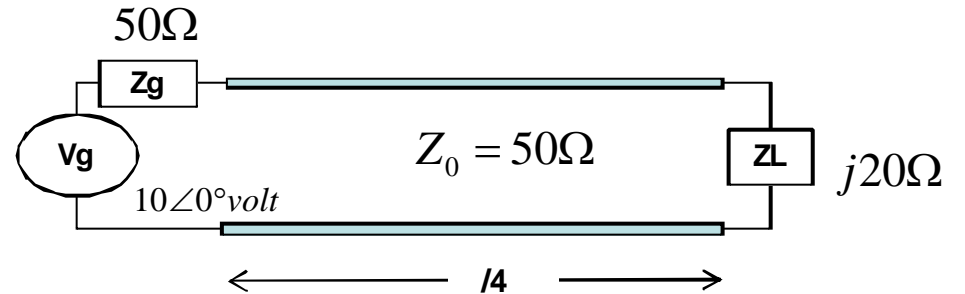
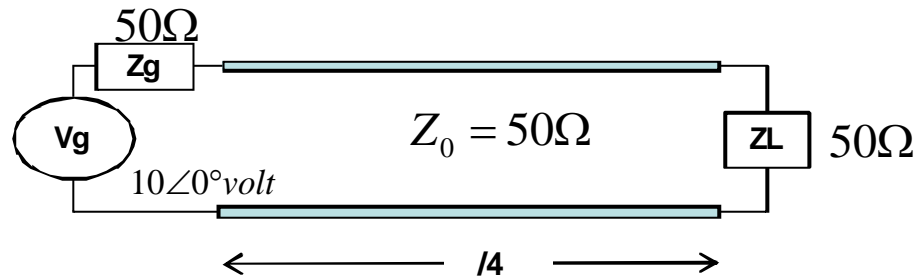

Goal of Transmission Line

Kesimpulan Kasus-kasus

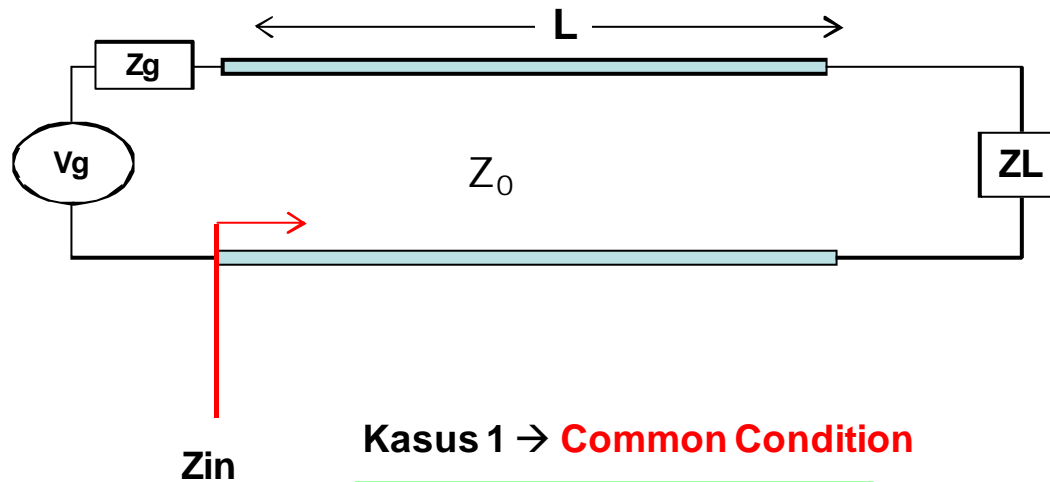

Kasus 1 → Common Condition

$Z_L = Z_0$ sehingga $Z_{in} = Z_0$
sayangnya $Z_{in} \neq Z_g^*$

Kasus 2 → Bad Condition

$Z_L \neq Z_0$ sehingga $Z_{in} \neq Z_0$
ditambah $Z_{in} \neq Z_g^*$

Kasus 3 → Preferred Condition

$Z_L \neq Z_0$ sehingga $Z_{in} \neq Z_0$
untungnya $Z_{in} = Z_g^*$

Kasus 4 → Ideal Condition

$Z_L = Z_0$ sehingga $Z_{in} = Z_0$
ditambah $Z_{in} = Z_g^*$

Questions???



