

DTG3F3  
Teknik Antena  
dan propagasi



# Susunan Antena

By : Dwi Andi Nurmantris



# Where Are We?



## 1. PENDAHULUAN

- Silabus, referensi, sasaran pengajaran
- Aturan penilaian: Quis, Ujian, Tugas dll
- Kontrak belajar : Aturan perkuliahan
- Sistem Komunikasi Radio Secara Umum
- Review electromagnetic dan Latar belakang sejarah
- Definisi dan Fungsi dasar antena
- Cara Kerja Antena
- Perkembangan Antena dan aplikasinya

## 2. KONSEP DASAR ANTENA

- Teorema Resiprositas
- Teorema daya dan intensitas radiasi
- Diagram arah dan diagram fasa
- Beamwidth Antena (lebar berkas)
- Frekuensi Kerja Antena, Impedansi antena, tahanan pancar, VSWR, Return Loss, dan Bandwidth Antena
- Direktivitas (pengarahan)
- Gain dan efisiensi antena
- Polarisasi Antena
- Konsep Aperture Antena
- Transmisi Friss

## 3. SUSUNAN ANTENA & IMPEDANSI GANDENG ANTENA

- Pengenalan Antena dipole dan monopole
- Pengenalan antena mikrostrip
- Pendahuluan susunan Antena (array antenna)
- Konsep dasar susunan dan prinsip perkalian diagram
- Susunan n-elemen sumber isotropic linier: persamaan medan, array factor, gain susunan
- Distribusi arus antena susunan linier uniform
- Distribusi arus antena susunan linier tak-uniform
- Susunan n-elemen sumber isotropic tak linier
- Impedansi Sendiri dan Impedansi Gandeng Antena
- Impedansi gandeng antar 2 antena
- Impedansi susunan n-Element identik

## 4. PENGENALAN SOFTWARE ANTENA DESIGN

- Pendahuluan Antenna design procedure
- Klasifikasi Computational Electromagnetic (CEM)
- Numerical Method: Time Domain Method dan Frequency Domain Method
- Pengenalan CST Microwave Studio

## 5. MACAM-MACAM ANTENA

- Antena Loop dan Helix (Perkembangan, Aplikasi, Karakteristik, dan Desain)
- Antena Horn (Perkembangan, Aplikasi, Karakteristik, dan Desain)
- Antena Reflektor (Perkembangan, Aplikasi, Karakteristik, dan Desain)
- Antena Yagi Uda (Perkembangan, Aplikasi, Karakteristik, dan Desain)

## 6. PENGUKURAN ANTENA

- Pendahuluan
- Persyaratan umum pengukuran antenna
- Teknik-teknik Pengukuran antenna
- Pengukuran diagram arah dan diagram fasa
- Pengukuran gain, direktifitas, efisiensi arus
- Pengukuran impedansi, SWR, BW, dan distribusi
- Pengukuran polarisasi antenna

# Contents



1

**Pendahuluan**

2

**Konsep Dasar Susunan**

3

**Macam-macam Susunan Antena**

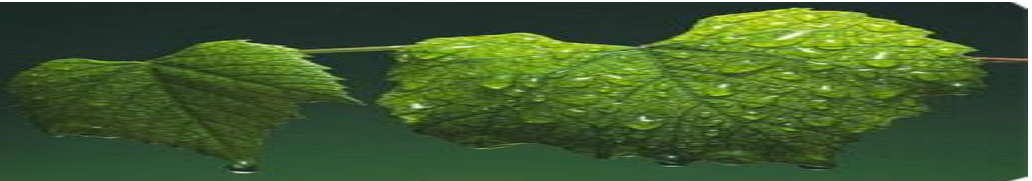
4

**Sistem Pencatuan Susunan Antena**

5

6

7



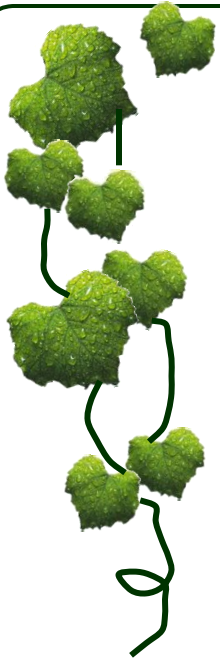
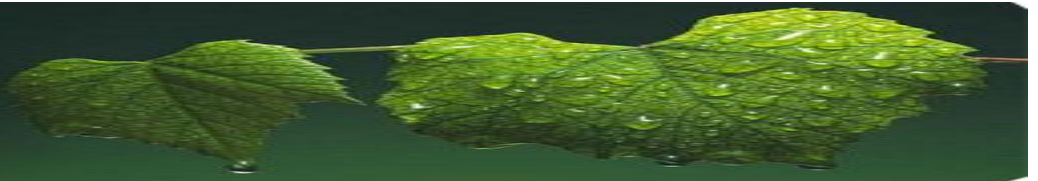
## **Very Large Array (VLA).**









**Radiotelescope situated in Socorro,  
New Mexico.**

**Works in the band of 1 to 25GHz**



# Where are We ?



-  **PENDAHULUAN** 
-  Konsep Dasar Susunan
-  Macam-macam susunan Antena
-  Sistem Pencatuan Susunan Antena
- 
- 
- 

# Pendahuluan

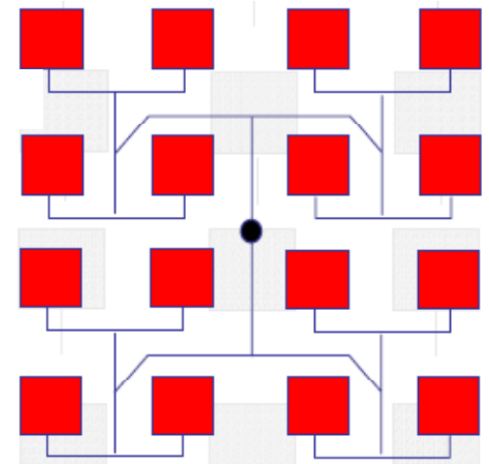
## Susunan Antena

- ❑ An array antenna is a spatially extended collection of **N similar radiating elements**, and the term "similar radiating elements" means that all the elements have the same radiation patterns, orientated in the same direction in 3D space.
- ❑ The elements are all fed with the same frequency.

## Tujuan Susunan Antena

Tujuan susunan antena adalah :

1. Meningkatkan gain antena
2. Mengontrol Sidelobe level
3. Mengatur pola pancar antena (beam forming)
4. Mengarahkan pola pancar ke arah tertentu (beam steering)



# Pendahuluan

Hal-hal yang mempengaruhi karakteristik antena array :

## 1. Geometri Susunan

- 1D array (Linear Array)
- 2D Array (Planar Array (Rectangular array, circular array) dan conformal array)
- 3D Array (Volume Array)

## 2. Jarak Antar Elemen

## 3. Elemen Array

- Element sejenis (bisa menggunakan perkalian diagram)
- Element tidak sejenis (Antena parasitik, antena log periodik)

## 4. Metoda pencatuan

### a) Berdasarkan jumlah elemen yang di catu

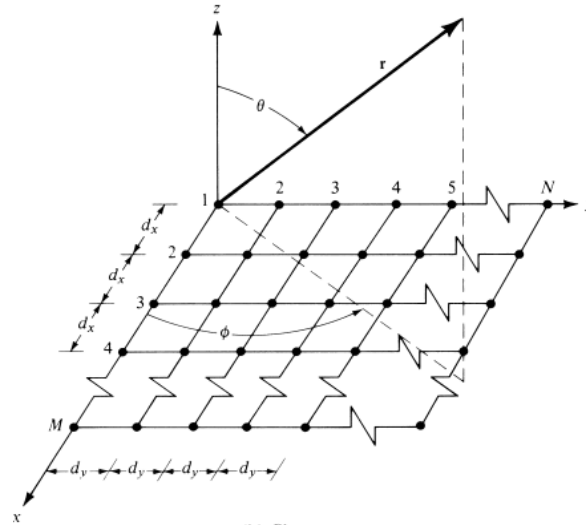
- Semua element dicatu
- Hanya driven element saja yang dicatu (antenna uda-yagi)

### b) Berdasarkan variasi sumber catuan

- Variasi Amplituda (Uniform, Binomial, Chebyshev)
- Variasi Phasa (Phased Array)

# Pendahuluan

## Geometri susunan antenna:



(b) Planar array

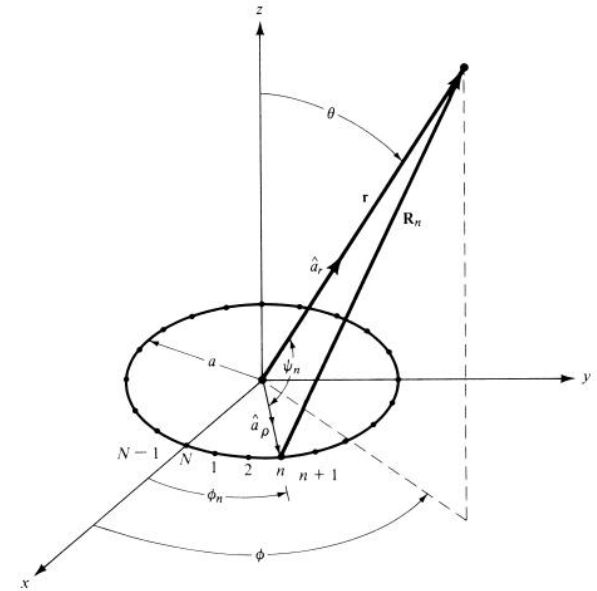


Figure 6.37 Geometry of an  $N$ -element circular array.

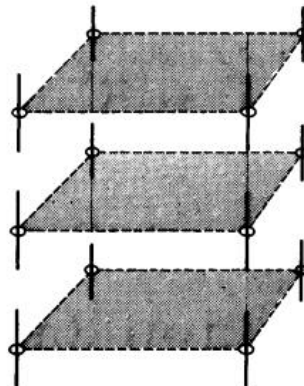
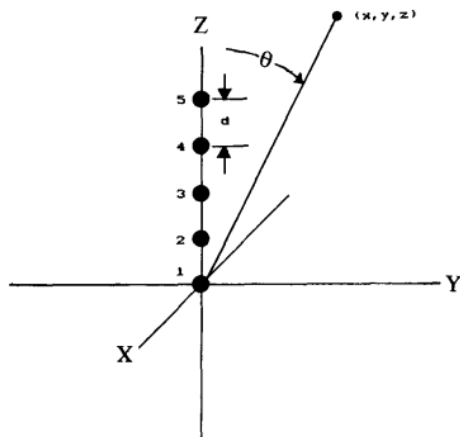


Fig. 7.2. Three-dimensional array of twelve identical elements.



# Pendahuluan

Array element sejenis dan tidak sejenis:

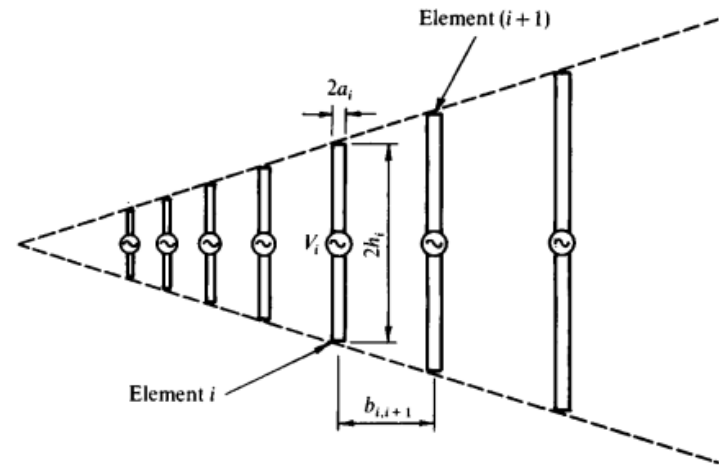
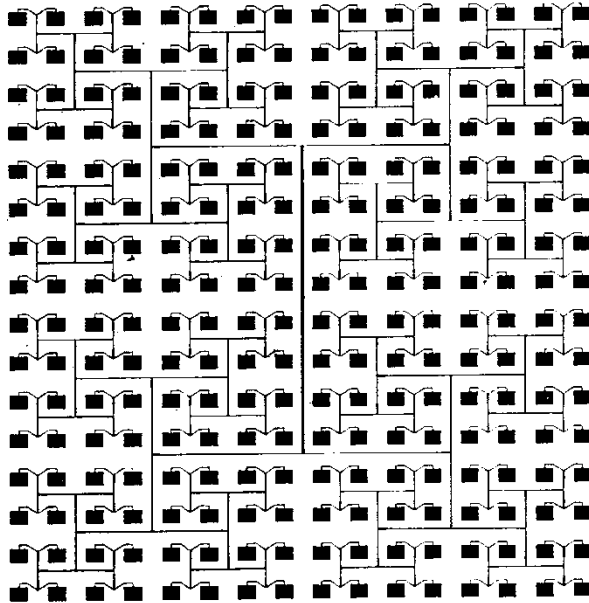


Fig. 6.29. Seven elements of an infinite log-periodic array.

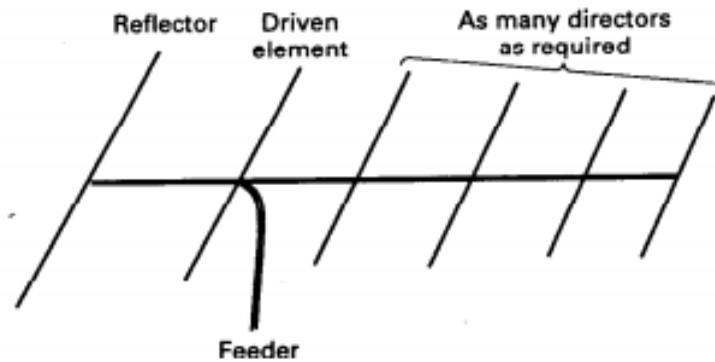


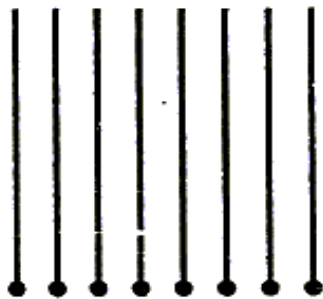
Fig. 4.2 A Yagi with a reflector and multiple directors.

# Pendahuluan

Efek variasi Amplitude arus catuan:



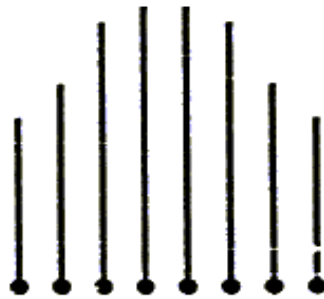
SLL = -13 dB  
HPBW = 12°  
Gain = 9.03 dBi



UNIFORM



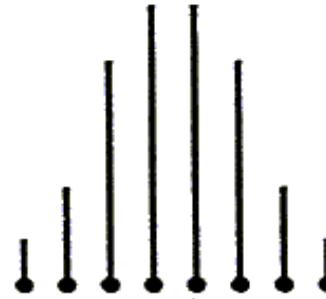
SLL = -20 dB  
HPBW = 14°  
Gain = 8.84 dBi



D-T



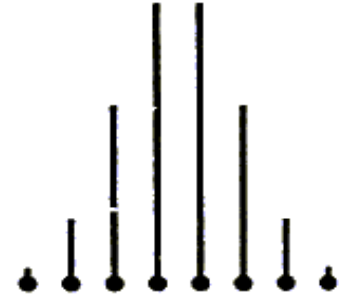
SLL = -40 dB  
HPBW = 18°  
Gain = 7.85 dBi



D-T



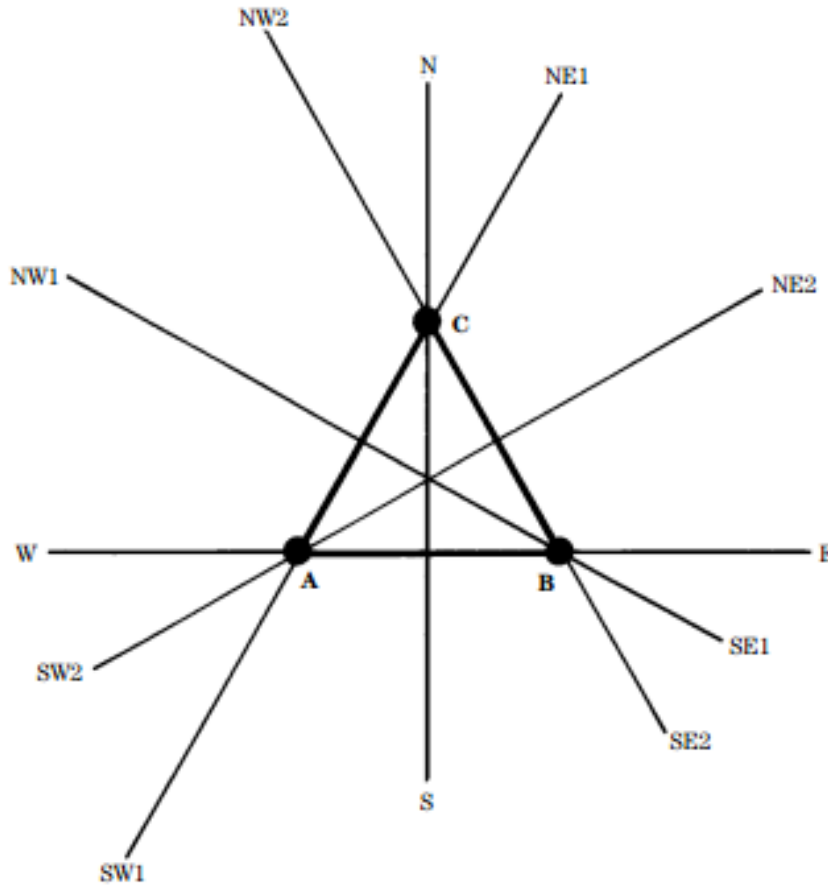
SLL =  $-\infty$  dB  
HPBW = 24°  
Gain = 6.79 dBi



BINOMIAL or DT

# Pendahuluan

## Efek variasi Phasa arus catuan:

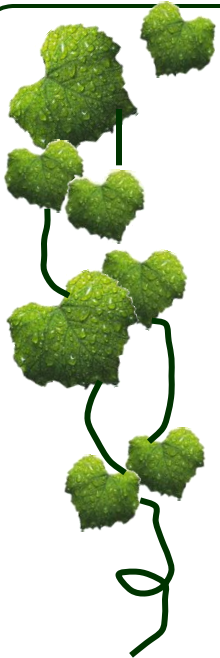
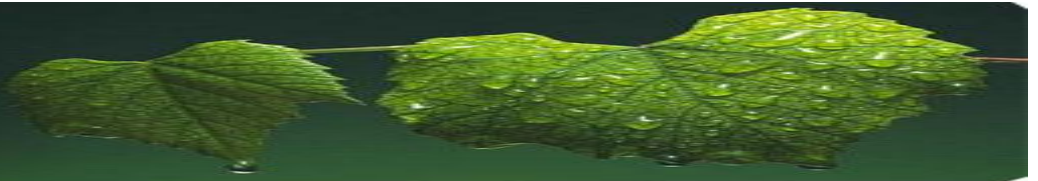


11-5A Three-element phased array.

Direction	Ant A	Ant B	Ant C
N-S	0°	0°	GND
NE1-SW1	0°	GND	180°
NE2-SW2	GND	0°	0°
E-W	0°	180°	GND
SE1-NW1	0°	GND	0°
SE2-NW2	GND	0°	180°

Table of feed phasing for the three-element array. Ant = antenna. GND = ground

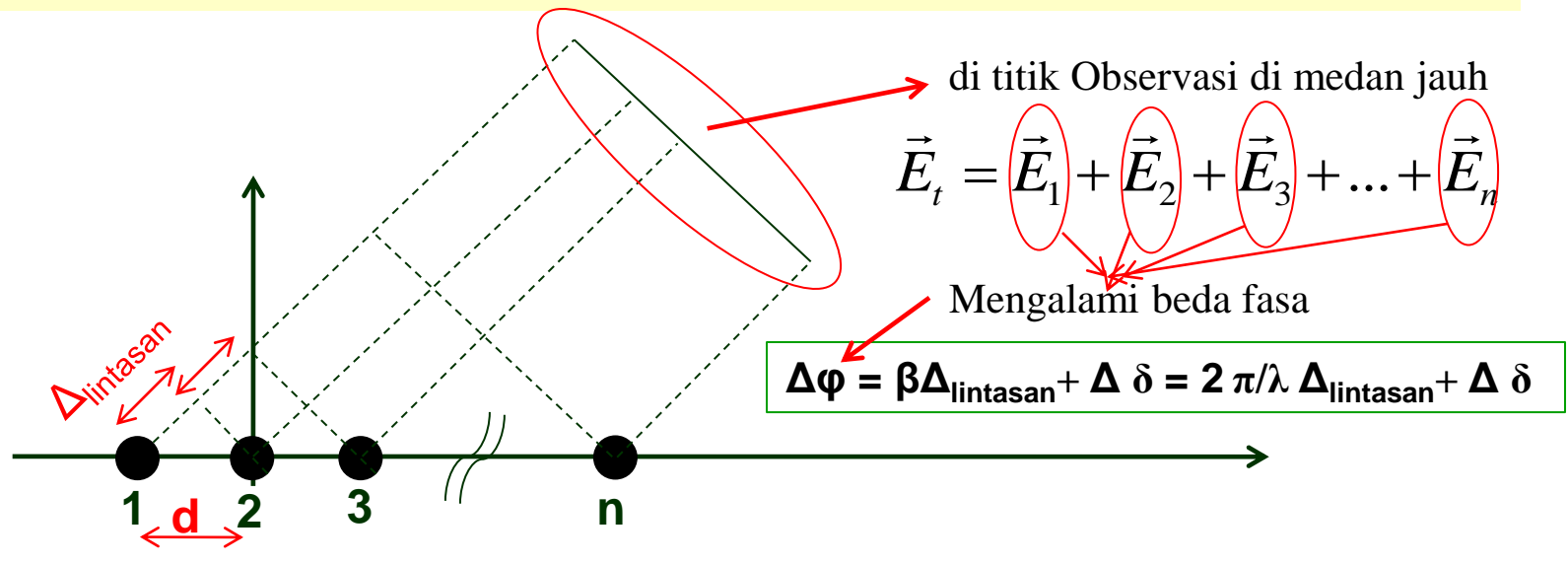
# Where are We ?



- 1 **PENDAHULUAN** 😊
- 2 **KONSEP DASAR SUSUNAN ANTENA** 😊
- 3 **Macam-macam susunan Antena**
- 4 **Sistem Pencatuan Susunan Antena**
- 5
- 6
- 7

# Konsep Dasar Susunan Antena

## Konsep Superposisi Gelombang



- ❑ Medan total dititik observasi medan jauh merupakan superposisi gelombang dari tiap-tiap gelombang yang berasal dari masing-masing elemen
- ❑ Pembentukan diagram arah dari suatu susunan antena di medan jauh tergantung dari **MAGNITUDA** dan **FASA** dari medan-medan yang dihasilkan masing-masing elemen antena.
- ❑ **MAGNITUDA** dari medan-medan dari masing-masing elemen bisa **Uniform** bisa juga **NonUniform**
- ❑ **FASA** dari medan-medan dari masing-masing element tergantung dari **Jarak relatif antar elemen (d)** dan **Beda Fasa catuan ( $\Delta\delta$ )** dari masing-masing elemen
- ❑ Jarak relatif antar elemen (d) → akan menyebabkan jarak tempuh gelombang tidak sama → di titik observasi medan jauh terjadi beda fasa antar gelombang yang dihasilkan tiap-tiap elemen

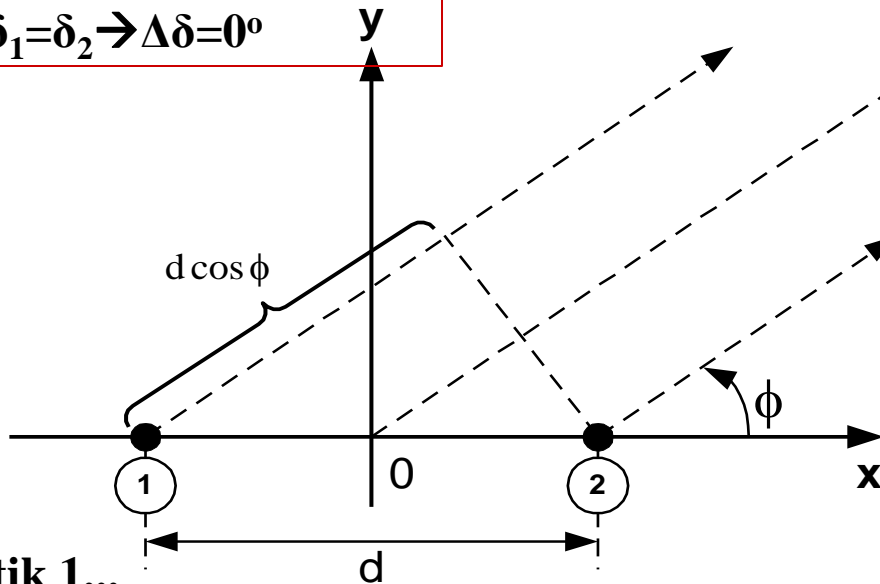
# Konsep Dasar Susunan Antena

## Susunan 2 Isotropis

### Kasus 1 : Magnitudo dan Fasa pencatutan sama

$$|I_1|=|I_2| \rightarrow |E_1|=|E_2|=E_0$$

$$\delta_1=\delta_2 \rightarrow \Delta\delta=0^\circ$$



- ❑ 2 sumber isotropis dipisahkan oleh jarak  $d$
- ❑ Titik observasi adalah ke arah sudut  $\phi$  dari sumbu horizontal (sumbu-x)
- ❑ Garis orientasi dari sumber-sumber isotropis menuju titik observasi dianggap sejajar karena  $d$  (jarak antar sumber isotropis)  $\ll$  daripada jarak antenna menuju titik observasi

### Referensi titik 1...

Jika titik 1 dianggap sebagai referensi (dianggap sbg titik dengan fasa = 0), maka  $E_2$  akan *mendahului* sebesar :

$$\varphi = \frac{2\pi}{\lambda} d \cos \phi$$

Sehingga, medan gabungan  $E_t$  dapat dituliskan sebagai berikut :

$$E_t = E_0 + E_0 e^{j\varphi}$$

# Konsep Dasar Susunan Antena

## Susunan 2 Isotropis

Kasus 1 : Magnitudo dan Fasa pencatuan sama

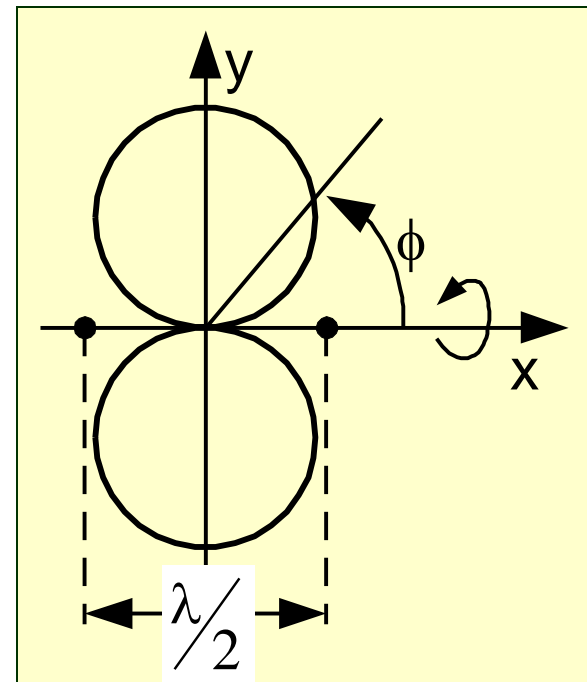
$$E_t = E_0 + E_0 e^{j\phi}$$

$$E_t = 2E_0 e^{j\frac{\phi}{2}} \left( \frac{e^{j\frac{\phi}{2}} + e^{-j\frac{\phi}{2}}}{2} \right)$$

$$E_t = 2E_0 \cos \frac{\phi}{2} e^{j\frac{\phi}{2}}$$

$$\phi = \frac{2\pi}{\lambda} d \cos \phi$$

$$E_t = \underbrace{2E_0 \cos \frac{\phi}{2}}_{\text{magnituda}} \underbrace{\angle \frac{\phi}{2}}_{\text{fasa}}$$



# Konsep Dasar Susunan Antena

## Susunan 2 Isotropis

**Kasus 2 : Magnitudo sama dan beda fasa pencatuan  $180^\circ$**

$$|I_1|=|I_2| \rightarrow |E_1|=|E_2|= E_0$$

$$\Delta\delta=\pi$$

$$E_t = 2E_0 \cos \frac{\varphi}{2} e^{j\frac{\varphi}{2}} \rightarrow$$

$$\text{Dimana : } \varphi = \frac{2\pi}{\lambda} d \cos \phi + \pi$$

**Magnitudonya**

$$E_t = 2E_0 \cos \left[ \frac{\pi}{\lambda} d \cos \phi + \frac{\pi}{2} \right]$$

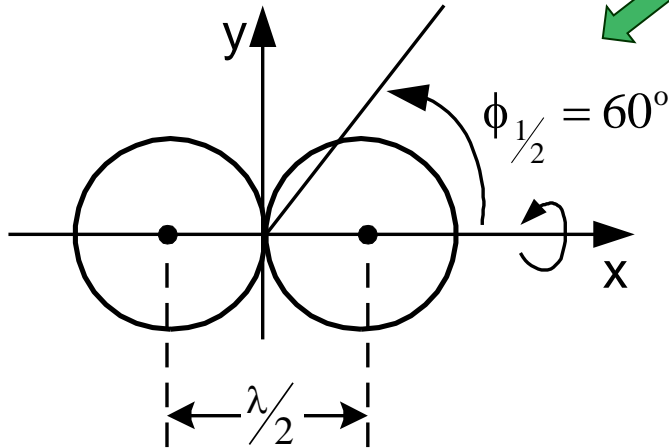
**Harga maksimum, misal  $d = \frac{1}{2}\lambda$**

$$\frac{\pi}{\lambda} d \cos \phi_m + \frac{\pi}{2} = 0$$

$$\frac{\pi}{2} \cos \phi_m = \pm (2k+1) \frac{\pi}{2} \rightarrow \phi_m = 0, \pi$$

**Harga Minimum, misal  $d = \frac{1}{2}\lambda$**

$$\frac{\pi}{2} \cos \phi_0 = \pm k\pi \rightarrow \phi_0 = \frac{\pi}{2}, \frac{3}{2}\pi$$





# Konsep Dasar Susunan Antena

## Susunan 2 Isotropis

**Kasus 3 : Magnitudo sama dan beda fasa pencatuan  $90^\circ$**

$$|I_1|=|I_2| \rightarrow |E_1|=|E_2|= E_0$$

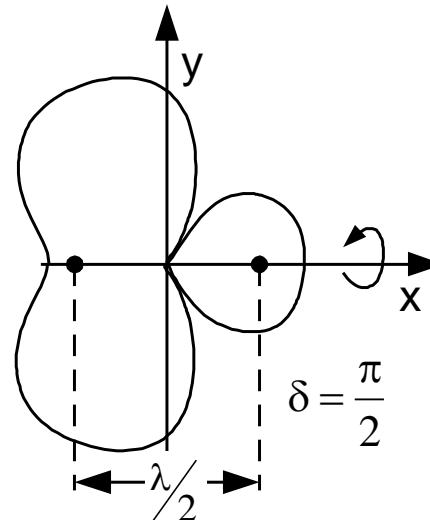
$$\Delta\delta = \pi/2$$

$$E_t = 2E_0 \cos \frac{\varphi}{2} e^{j\frac{\varphi}{2}} \rightarrow$$

**Magnitudonya**

$$E_t = 2E_0 \cos \left[ \frac{\pi}{\lambda} d \cos \phi + \frac{\pi}{4} \right]$$

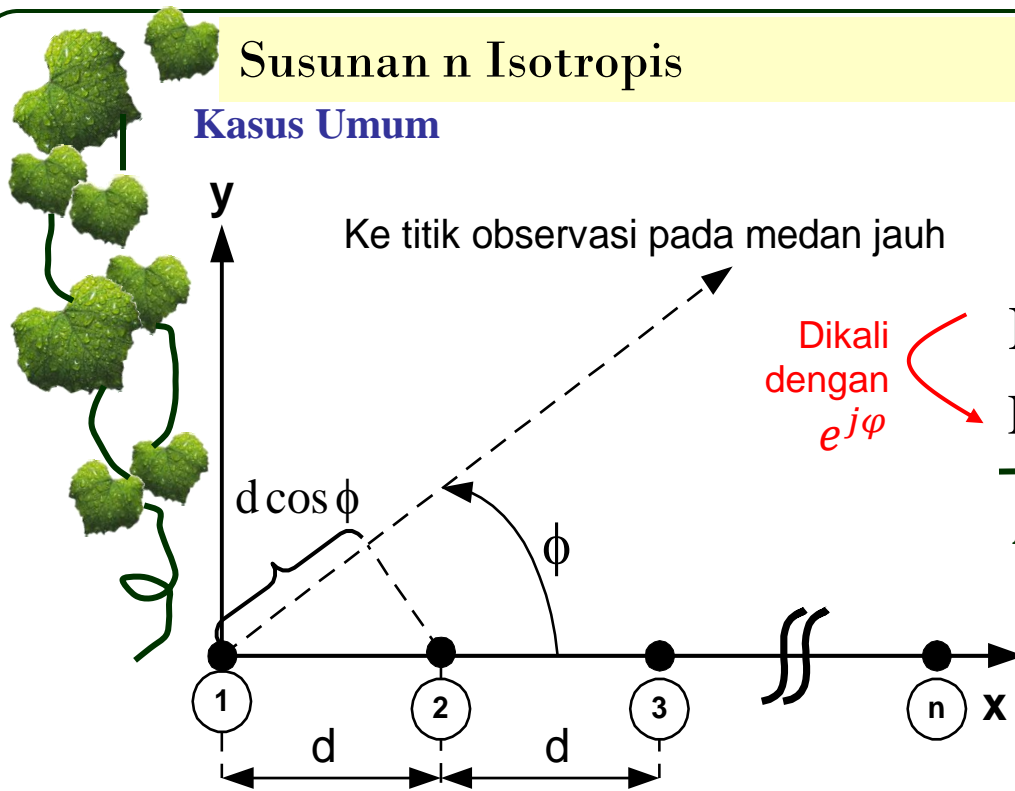
Dimana :  $\varphi = \frac{2\pi}{\lambda} d \cos \phi + \frac{\pi}{2}$



# Konsep Dasar Susunan Antena

## Susunan n Isotropis

### Kasus Umum



Dengan dinormalisasikan terhadap  $E_0$ ,

Dikali  
dengan  
 $e^{j\varphi}$

$$E_{tn} = 1 + e^{j\varphi} + e^{j2\varphi} + \dots + e^{j(n-1)\varphi}$$

$$E_{tn} e^{j\varphi} = e^{j\varphi} + e^{j2\varphi} + e^{j3\varphi} + \dots + e^{jn\varphi}$$

$$E_{tn}(1 - e^{j\varphi}) = 1 - e^{jn\varphi}$$



Didapatkan,

- Referensi titik 1

$$E_t = E_0 + E_0 e^{j\varphi} + E_0 e^{2j\varphi} + \dots + E_0 e^{j(n-1)\varphi}$$

$$E_{tn} = \frac{1 - e^{jn\varphi}}{1 - e^{j\varphi}} = \frac{e^{jn\frac{\varphi}{2}}}{e^{j\frac{\varphi}{2}}} \left( \frac{e^{-jn\frac{\varphi}{2}} - e^{jn\frac{\varphi}{2}}}{e^{-j\frac{\varphi}{2}} - e^{j\frac{\varphi}{2}}} \right)$$

# Konsep Dasar Susunan Antena

## Susunan $n$ Isotropis Kasus Umum

Sehingga, didapatkan medan total ternormalisasi untuk referensi pada titik 1

$$E_{\text{tn}} = \frac{\sin\left(n \frac{\varphi}{2}\right)}{\sin\left(\frac{\varphi}{2}\right)} \angle \zeta$$

dimana,  $\zeta = \frac{n-1}{2} \varphi$

dan,  $\varphi = \frac{2\pi}{\lambda} \cos \phi + \delta$

$d$  = jarak spasi antar elemen

$\delta$  = beda fasa antar catuan arus yang berdekatan

## Magnitudonya

- Medan maksimum terjadi jika *suku penyebut sama dengan atau mendekati nol*

$$\sin\left(\frac{\varphi}{2}\right) \rightarrow 0 \text{ atau } \left(\frac{\varphi}{2}\right) \rightarrow 0 \text{ atau } \boxed{\varphi = 0}$$

Jika  $\varphi$  tidak pernah mencapai harga nol, maka medan maksimum terjadi jika  $\varphi$  mencapai harga minimum

- Medan minimum terjadi jika *suku pembilang sama dengan nol*

$$\sin\left(n \frac{\varphi}{2}\right) = 0 \text{ atau } n \frac{\varphi}{2} = \pm k\pi \Big|_{k=0,1,2,\dots \text{dst}}$$

# Konsep Dasar Susunan Antena

## Susunan n Isotropis Kasus Umum

### Array Factor ...

*Array factor adalah normalisasi medan total susunan antena terhadap nilai maksimum dari medan total susunan tersebut*

$$\text{Array Factor} = \text{AF} = E_N = \frac{E_t}{E_{\text{tmaks}}}$$

$$E_{\text{tn}} = \frac{\sin\left(n \frac{\varphi}{2}\right)}{\sin\left(\frac{\varphi}{2}\right)} \left(\frac{n-1}{2}\right) \varphi$$

$$\varphi = \frac{2\pi}{\lambda} d \cos \phi + \Delta \delta$$

$E_{\text{tmaks}}$  tercapai pada  $\varphi$  mendekati 0

$$E_{\text{tmaks}} = \lim_{\varphi \rightarrow 0} \frac{\sin\left(n \frac{\varphi}{2}\right)}{\sin\left(\frac{\varphi}{2}\right)} = n \Rightarrow E_N = \frac{E_{\text{tn}}}{E_{\text{tmax}}}$$

### Array Factor

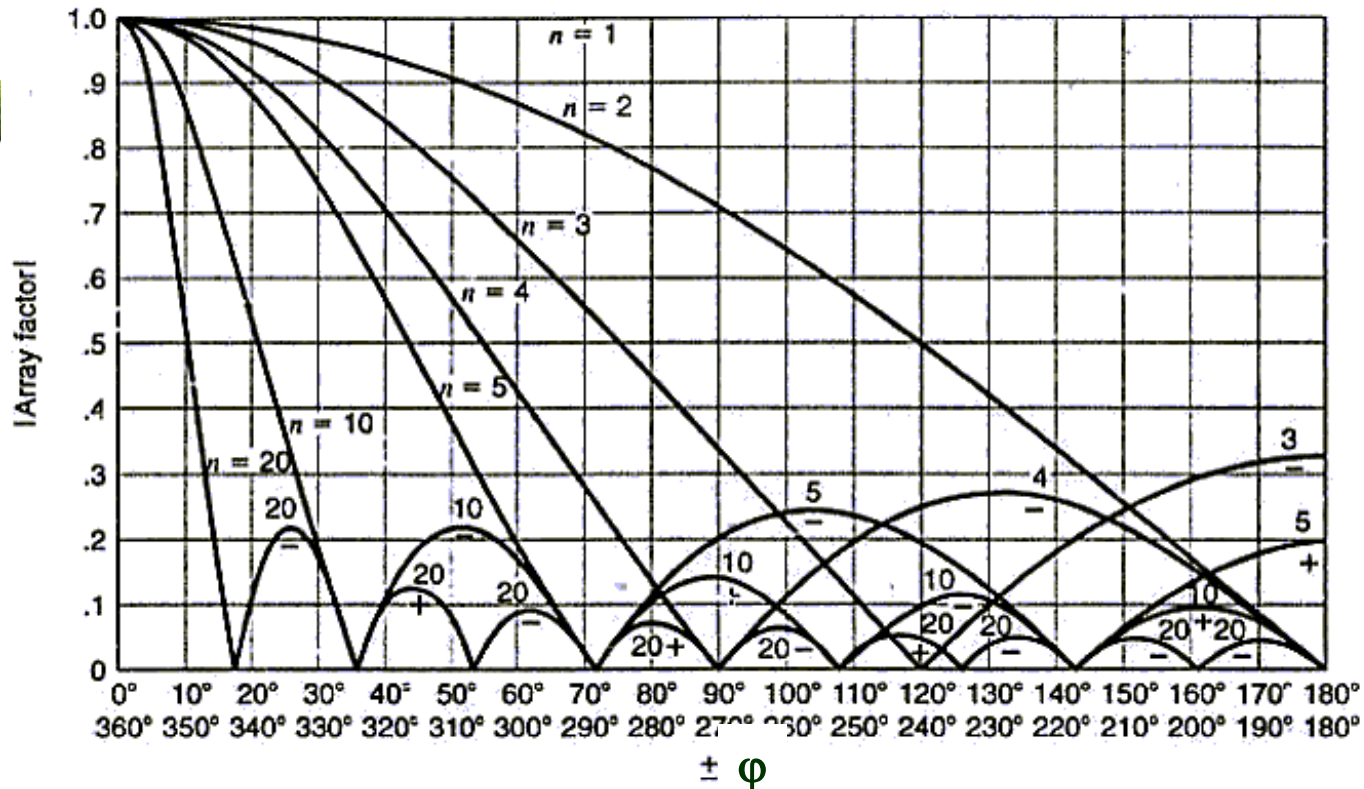
$$E_N = \frac{1}{n} \frac{\sin\left(n \frac{\varphi}{2}\right)}{\sin\left(\frac{\varphi}{2}\right)}$$

# Konsep Dasar Susunan Antena

## Susunan $n$ Isotropis Kasus Umum

### Array Factor ...

Faktor susunan (untuk sejumlah sumber) dapat digambarkan sebagai fungsi  $\phi$ . Jika  $\phi$  adalah merupakan fungsi  $\phi$ , maka nilai dari faktor susunan dan pola medan akan dapat langsung diketahui dari grafik di bawah ini !



# Konsep Dasar Susunan Antena

## Susunan n Isotropis

Gain Susunan (distribusi arus catuan uniform)



	1	1	2	3	...	n
	●	●	●	●	●	●
Perbandingan Daya	$W_o$	$\frac{W_o}{n}$	$\frac{W_o}{n}$	$\frac{W_o}{n}$	...	$\frac{W_o}{n}$
Perbandingan Medan	$ E_1  = E_0$	$\frac{E_0}{\sqrt{n}}$	$\frac{E_0}{\sqrt{n}}$	$\frac{E_0}{\sqrt{n}}$	...	$\frac{E_0}{\sqrt{n}}$
		$E_{t maks} = n \left  \frac{E_0}{\sqrt{n}} \right  = E_0 \sqrt{n}$				

Sehingga,

- Penguatan Medan

$$G_F = \frac{E_0 \sqrt{n}}{E_0} = \sqrt{n}$$

- Penguatan Daya

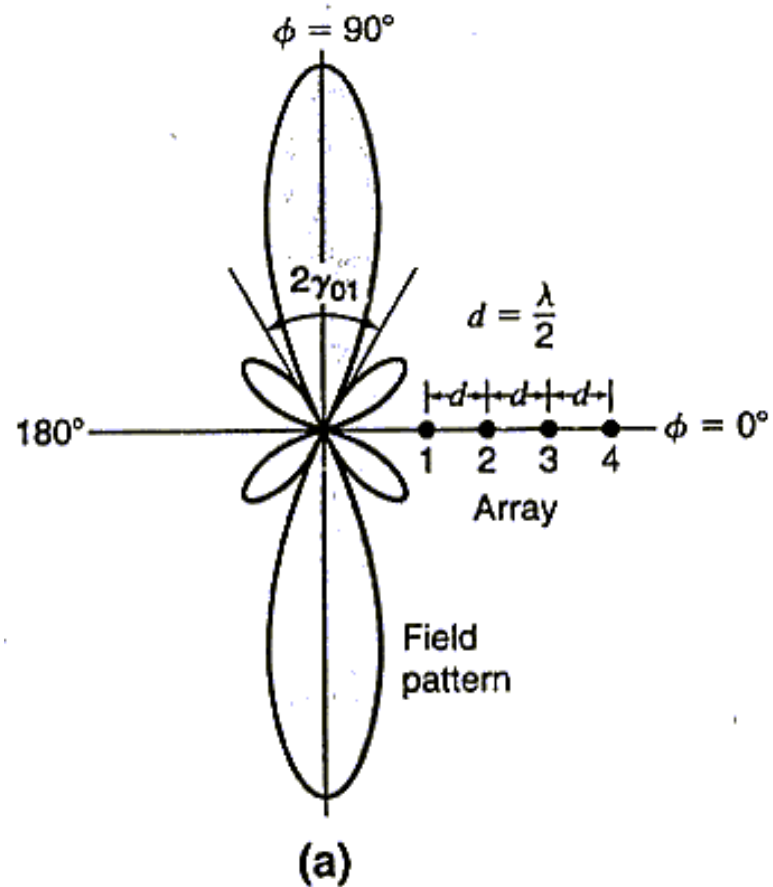
$$G = (G_F)^2 = n$$

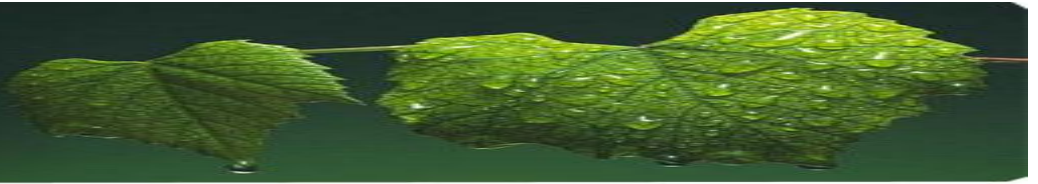
# Konsep Dasar Susunan Antena

## Kasus 1

(Utk Distribusi Arus Uniform) – Susunan Broadside

$$n = 4, d = \frac{\lambda}{2}, \delta = 0$$



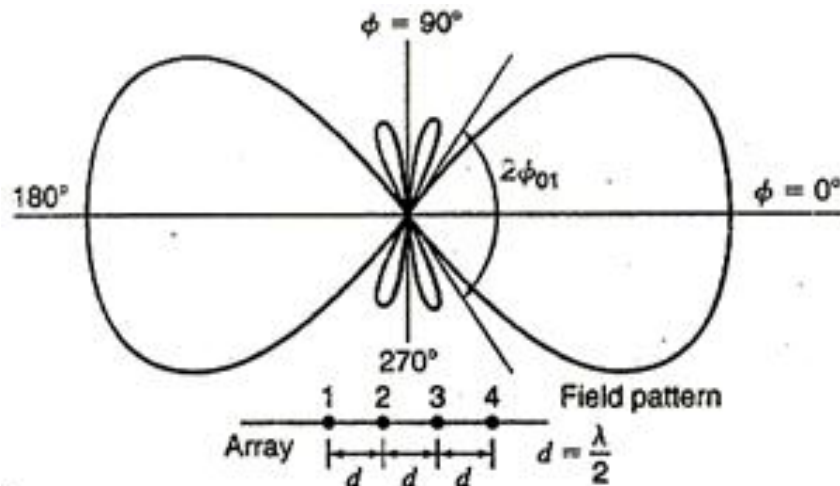


## Kasus 2

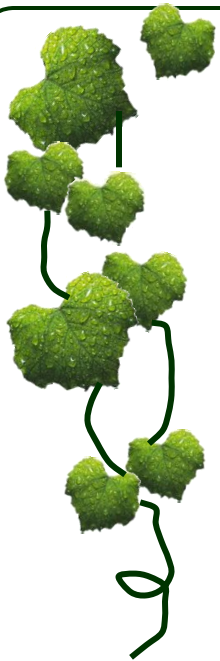
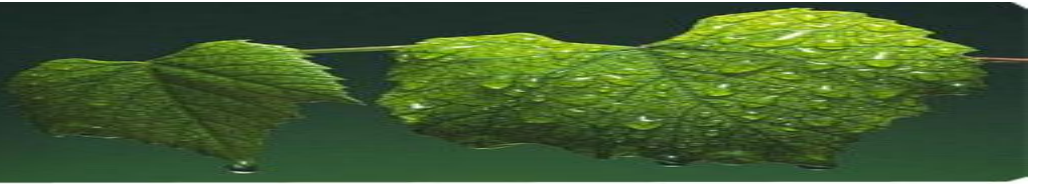
(Utk Distribusi Arus Uniform) – Susunan Endfire Biasa

- Untuk  $n = 4$ ,  $d = \lambda/2$ , didapat :

$$\delta = -\pi$$



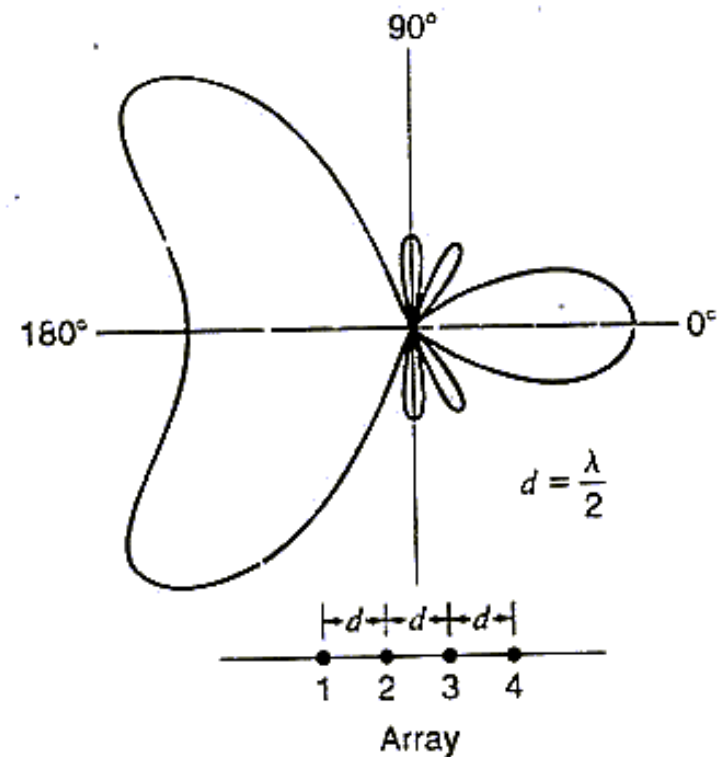




### Kasus 3

(Utk Distribusi Arus Uniform) – Susunan Endfire Hansen-Woodyard Dengan Direktifitas Diperbesar

$$n = 4, d = \frac{\lambda}{2}, \text{ dan } \delta = -\frac{5}{4}\pi$$



# Pendahuluan

## Prinsip Perkalian Diagram:

- Pada susunan antena yang sejenis, dapat dipakai **PRINSIP PERKALIAN DIAGRAM**
- *Antena sejenis adalah antena yang memiliki diagram arah medan dan fasa yang sama, dan orientasinya juga sama.*
- Susunan dari sejumlah  $n$  antena-antena sejenis, dapat diperhatikan sebagai susunan sejumlah  $n$  sumber isotropik dengan catuan arus dan fasa tertentu, sehingga memiliki *Diagram Arah dan Diagram Fasa yang terkoreksi* dari diagram susunan isotropiknya.
- Untuk susunan **TAK ISOTROPIK DAN/ATAU TAK SEJENIS** **TIDAK BERLAKU PRINSIP PERKALIAN DIAGRAM**

# Konsep Dasar Susunan Antena

## Prinsip Perkalian Diagram:



### EXAMPLE 5-3.1

Assume two identical point sources separated by a distance  $d$ , each source having the field pattern given by (1) as might be obtained by two short dipoles arranged as in Fig. 5-7. Let  $d = \lambda/2$  and the phase angle  $\delta = 0$ . Then the total field pattern is

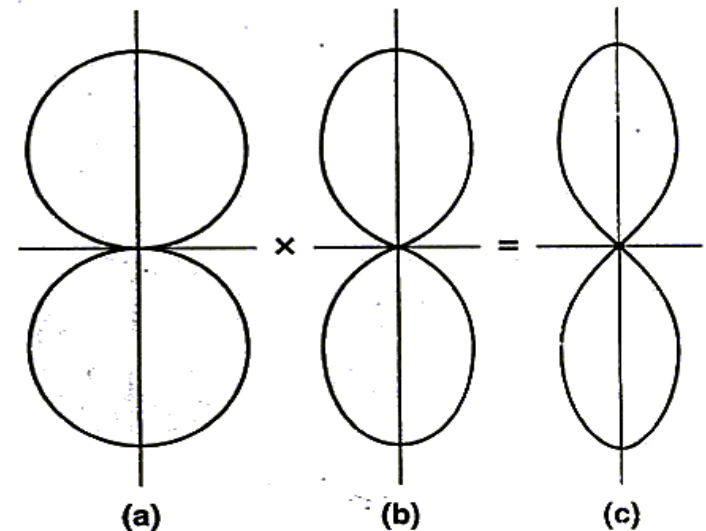
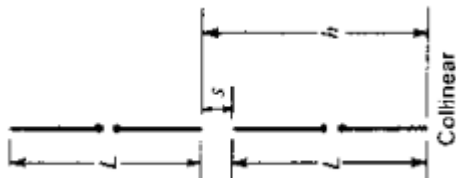
$$E = \sin \phi \cos \left( \frac{\pi}{2} \cos \phi \right) \quad (5)$$

This pattern is illustrated by Fig. 5-8c as the product of the individual source pattern ( $\sin \phi$ ) shown at (a) and the array pattern  $\{\cos[(\pi/2) \cos \phi]\}$  as shown at (b). The pattern is sharper than it was in Case 1 (Sec. 5-2) for the isotropic sources. In this instance, the maximum field of the individual source is in the direction  $\phi = 90^\circ$ , which coincides with the direction of the maximum field for the array of two isotropic sources.

JD Krauss, Marhefka, RJ,  
 “Antennas For All Applications”,  
 McGraw-Hill, 2002 page-100 →  
**KOLINIER**

**Figure 5-8**

Example of pattern multiplication. Two nonisotropic but identical point sources of the same amplitude and phase, spaced  $\lambda/2$  apart and arranged as in Fig. 5-7, produce the pattern shown at (c). The individual source has the pattern shown at (a), which, when multiplied by the pattern of an array of two isotropic point sources (of the same amplitude and phase) as shown at (b), yields the total array pattern of (c).



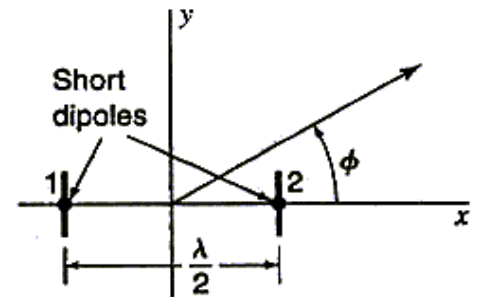
# Konsep Dasar Susunan Antena

## Prinsip Perkalian Diagram:

JD Krauss, Marhefka, RJ, "Antennas For All Applications",  
McGraw-Hill, 2002 page-101 → **SIDE BY SIDE**

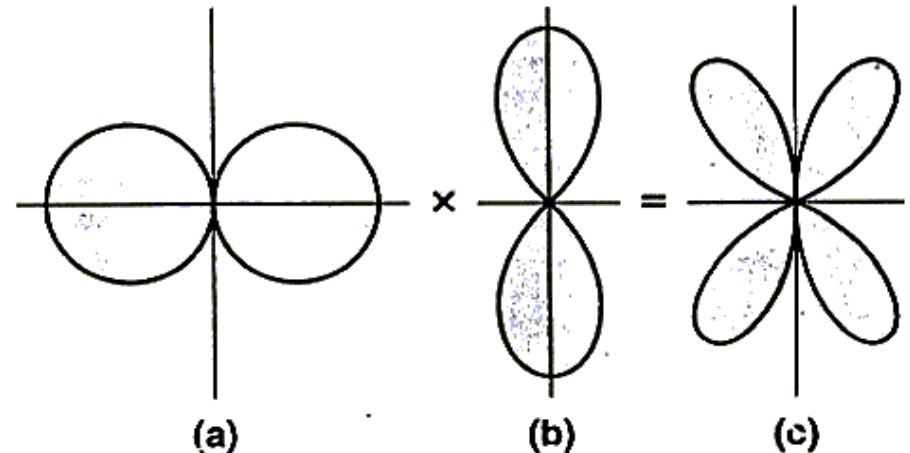
**Figure 5-9**

Array of two nonisotropic sources with respect to the coordinate system.

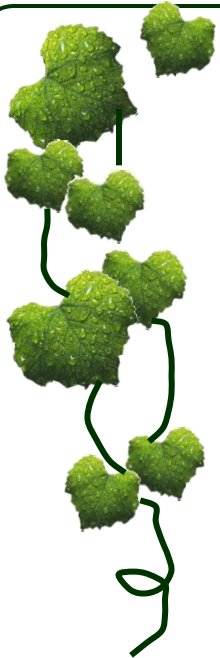
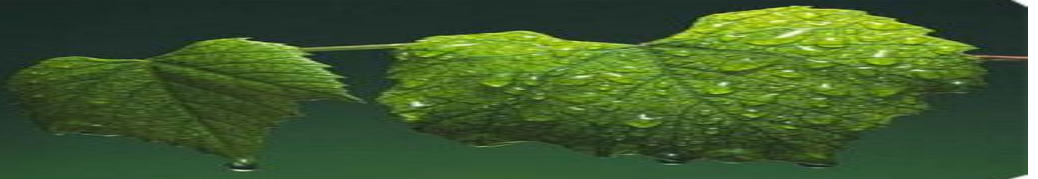






**Figure 5-10**

Example of pattern multiplication.  
Total array pattern (c) as the product of pattern (a) of individual nonisotropic source and pattern (b) of array of two isotropic sources. The pattern (b) for the array of two isotropic sources is identical with that of Fig. 5-8b, but the individual source pattern (a) is rotated through  $90^\circ$  with respect to the one in Fig. 5-8a.



# Where are We ?



-  **PENDAHULUAN** 
-  **KONSEP DASAR SUSUNAN ANTENA** 
-  **MACAM-MACAM SUSUNAN ANTENA** 
-  **Sistem Pencatuan Antena**
- 
- 
- 

# Macam-macam Susunan Antena

## Macam-macam Susunan Antena:

Macam-macam susunan antena bisa dilihat berdasarkan:

### 1. Geometri Susunan

- 1D array (Linear Array)
- 2D Array / Planar Array (Rectangular array, circular array)
- 3D Array (Volume Array)

### 3. Elemen Array

- Element sejenis (bisa menggunakan perkalian diagram)
- Element tidak sejenis (Antena parasitik, antena log periodik)

### 4. Metoda pencatuan

- a) Berdasarkan jumlah elemen yang di catu
  - Semua element dicatu
  - Hanya driven elemen saja yang dicatu (antenna uda-yagi)
- b) Berdasarkan variasi sumber catuan
  - Variasi Amplituda (Uniform, Binomial, Chebiscev)
  - Variasi Phasa (Phased Array)

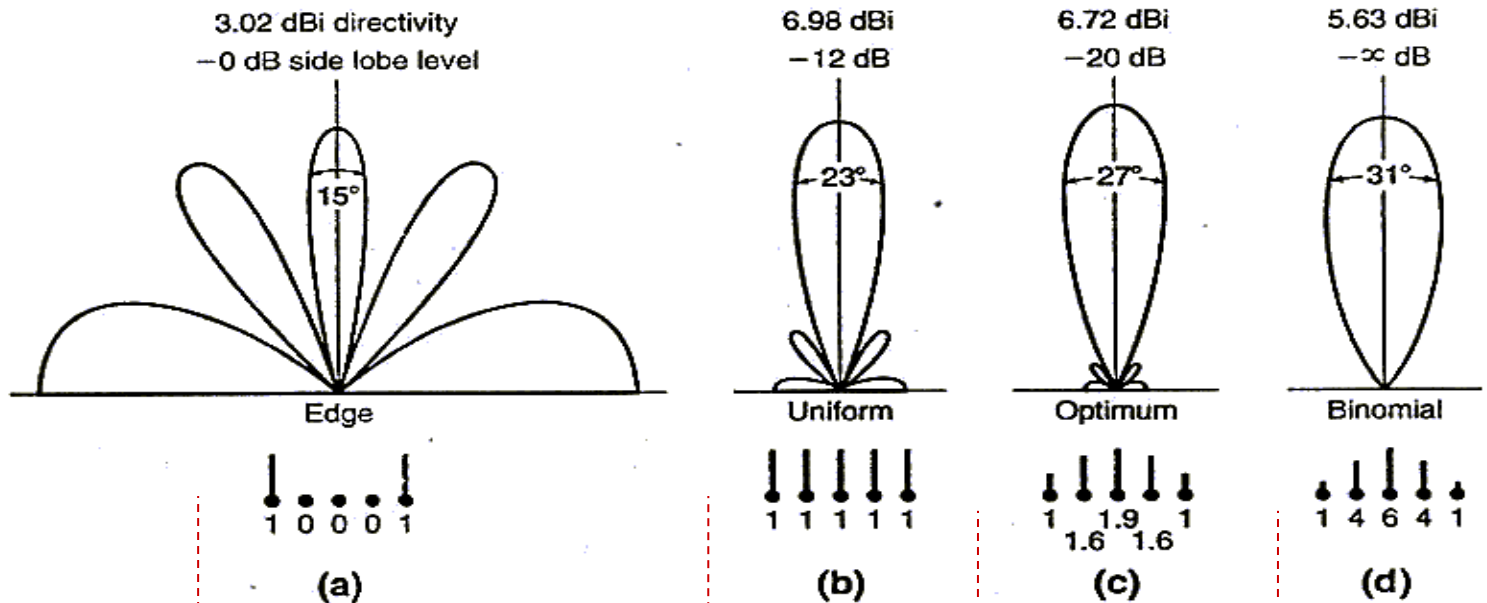
### 5. System Network

- Passive array
- Active array
- Adaptative array

# Macam-macam Susunan Antena

Variasi amplitudo catuan pada antena array (Distribusi Uniform, Binomial, dan dolph-chebisev):

Five source array in order of decreasing side-lobe level



Perbandingan Arus/Medan

1:0:0:0:1

1:1:1:1:1

1:1.6:1.9:1.6:1

1:4:6:4:1

Perbandingan Daya

1<sup>2</sup>:0<sup>2</sup>:0<sup>2</sup>:0<sup>2</sup>:1<sup>2</sup>

1<sup>2</sup>:1<sup>2</sup>:1<sup>2</sup>:1<sup>2</sup>:1<sup>2</sup>

1<sup>2</sup>:1.6<sup>2</sup>:1.9<sup>2</sup>:1.6<sup>2</sup>:1<sup>2</sup>

1<sup>2</sup>:4<sup>2</sup>:6<sup>2</sup>:4<sup>2</sup>:1<sup>2</sup>

Gain

$$G_f = \frac{1+0+0+0+1}{\sqrt{1^2+0^2+0^2+0^2+1^2}} = \frac{2}{\sqrt{2}} = 1,414$$

?

?

?

# Macam-macam susunan Antena

## Distribusi amplitude arus catuan Binomial:

- Distribusi arus Binomial disebut juga sebagai Distribusi John Stone
- Susunan dgn distribusi ini berarti urutan amplituda arus harus sebanding dengan koefisien-koefisien pada deret suku banyak yang memenuhi :

**Table**

$n$	Relative amplitudes (Pascal's triangle)						
3			1	2	1		
4			1	3	3	1	
5			1	4	6	4	1
6		1	5	10	10	5	1

$$(a+b)^{n-1} = a^{n-1} + (n-1)a^{n-2}b + \frac{(n-1)(n-2)}{2!}a^{n-3}b^2 + \dots dst$$

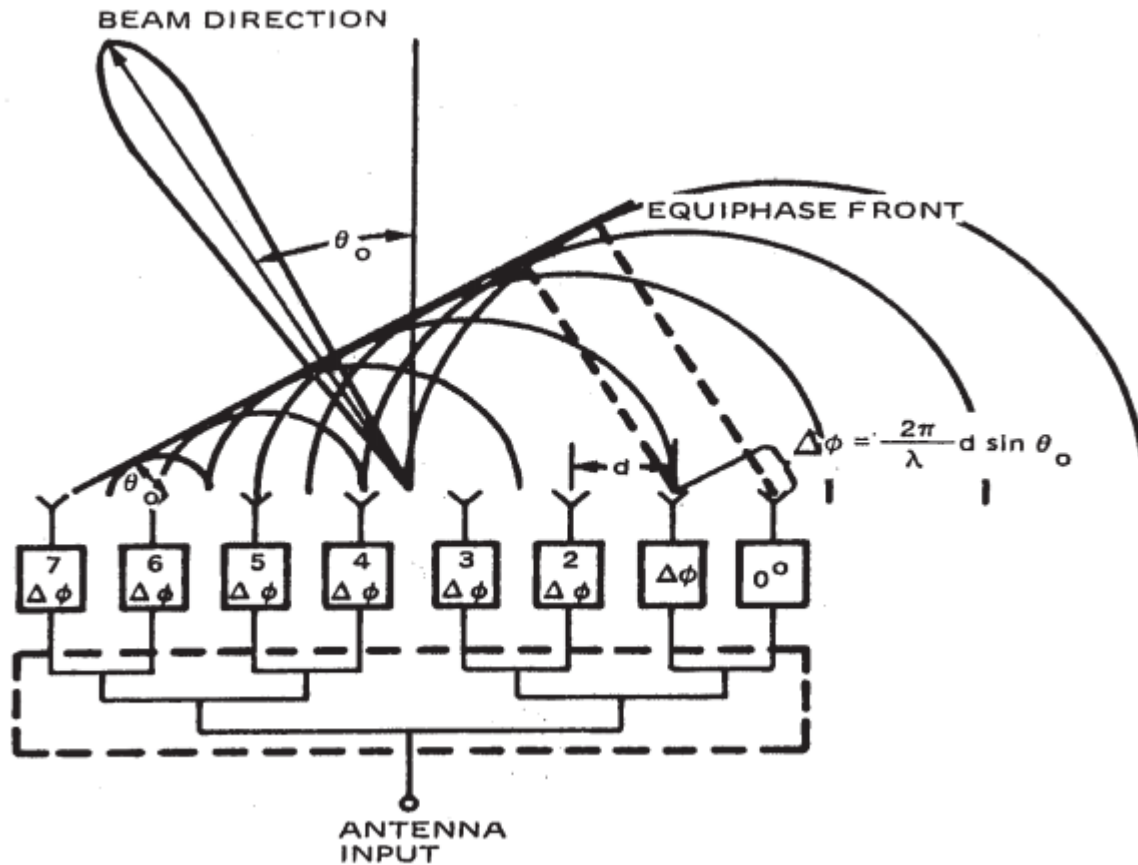
Koefisien-koefisien tersebut membentuk Deret Segitiga Pascal

- Sifat pengarahan yang didapatkan : (1) perbandingan mayor terhadap minor lobe  $\rightarrow \infty$ , (2) lebar berkas mainlobe cukup besar



# Macam-macam Susunan Antena

## Phased Array

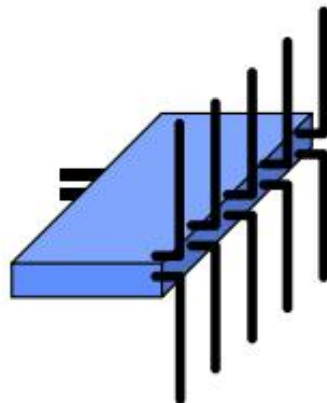


# Pendahuluan

## Network System → passive array

Use a feeding network with passives elements (power divider, transmission lines, matching network etc.)

- The radiation pattern and polarization are fixed.
- Work as a unique antenna.
- Depending on the network
  - » A single beam
  - » multibeam
- Can have different input terminals in the network (multi-diagram or multibeam antenna).
- Are reciprocal, works in transmission and reception.

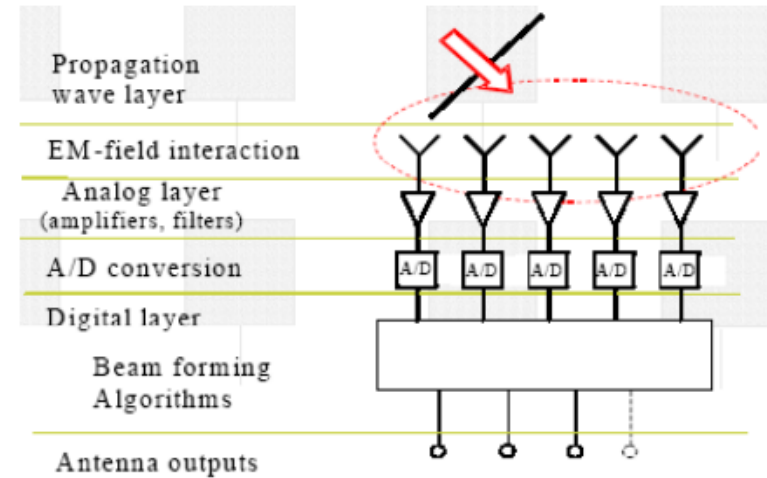
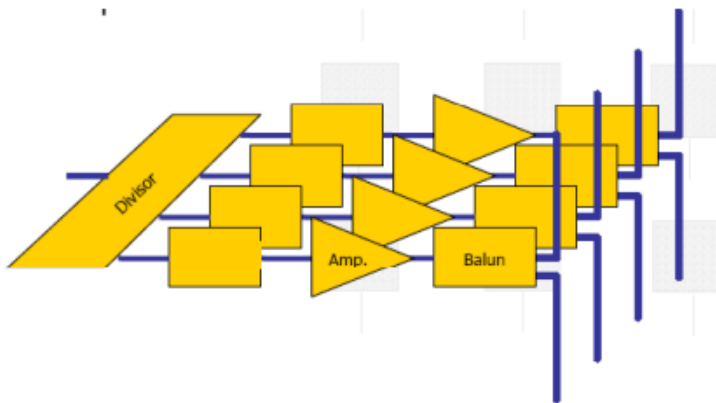


# Pendahuluan

## Network System → Active array

Linear active network to feed the arrays

- Allow amplified distribution in the antenna
- Allow active control of the excitations and of the radiation patterns.
- Allow signal processing



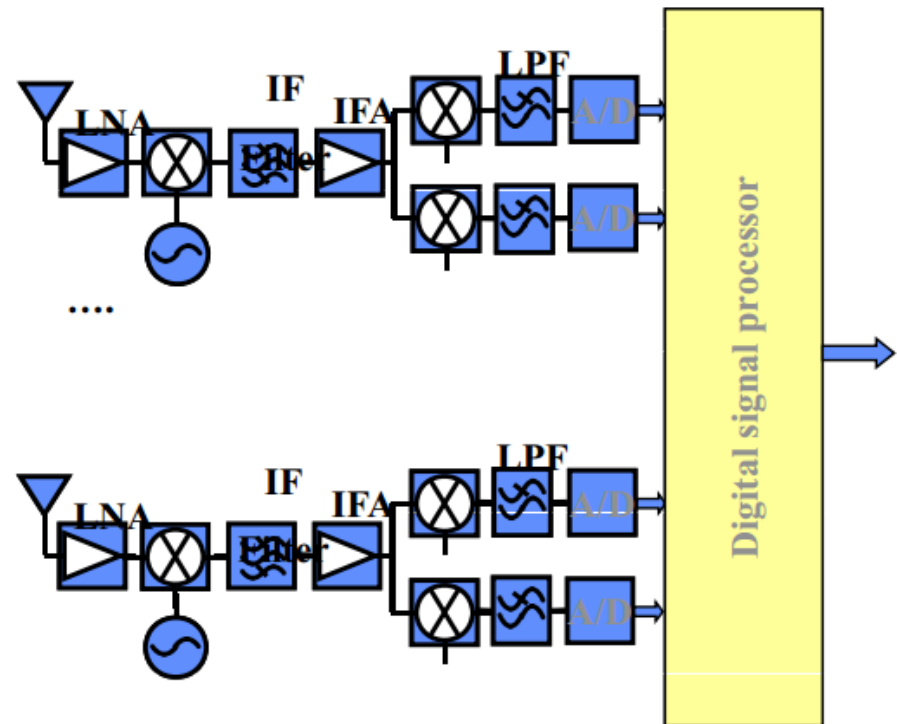
**The active arrays are antennas with variable phase, that allow beam steering in a variable direction (very useful in Radar systems).**

# Pendahuluan

## Network System → Adaptive array

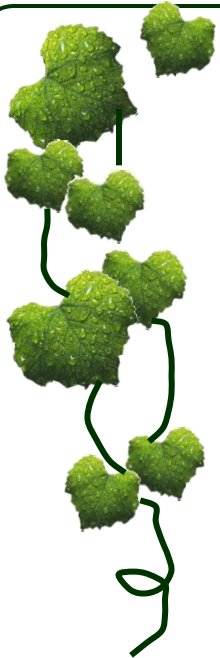
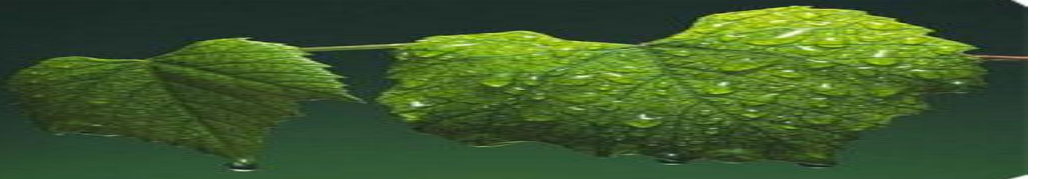
A digital processor allow:












- Digital control of patterns
- Patterns dependent of
  - » frequency
  - » time
  - » code
- Simultaneous variables patterns



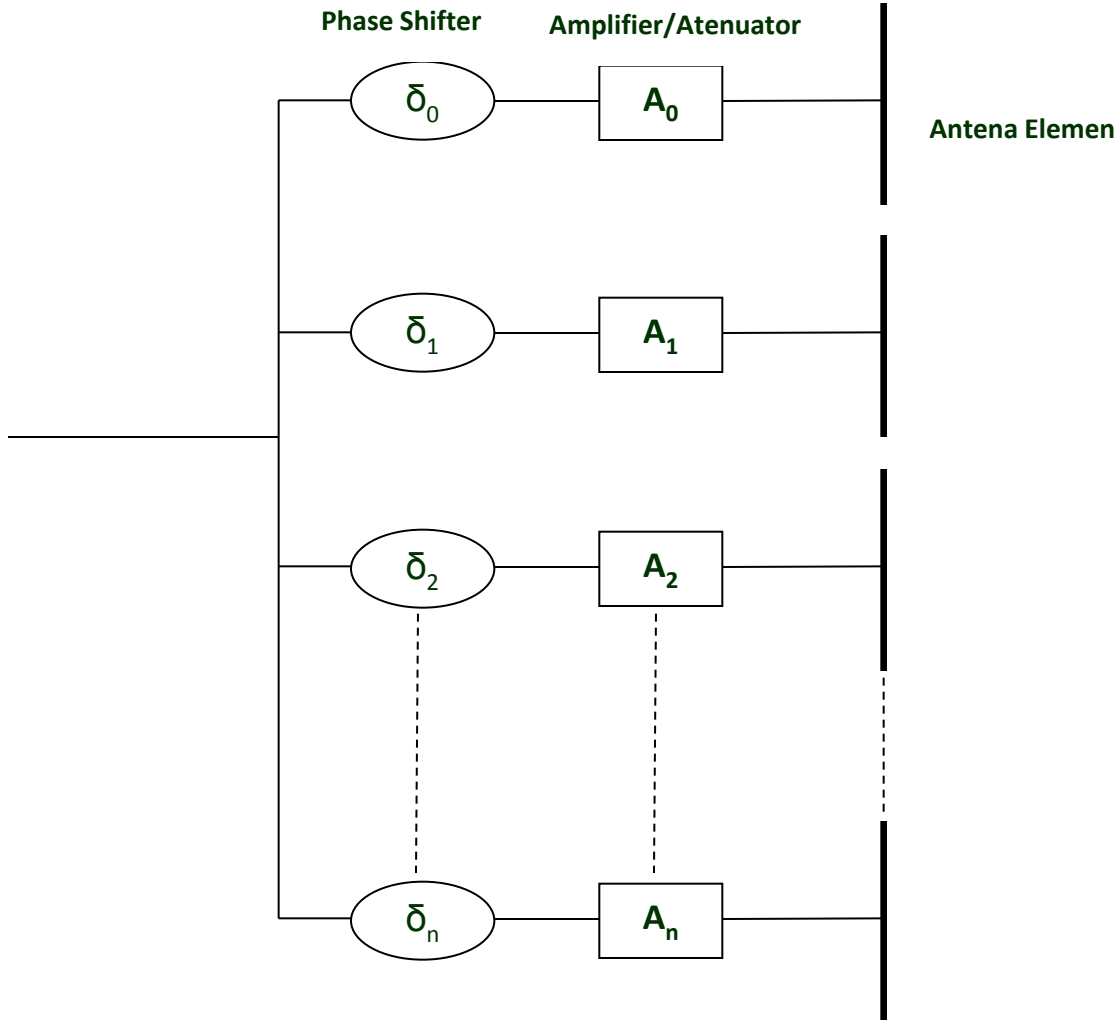
**The adaptive arrays are kind of antennas that works with active feeding modifying instantaneously the radiation pattern depending of the signal that it receives (These antennas are very useful in communication systems)**

# Where are We ?

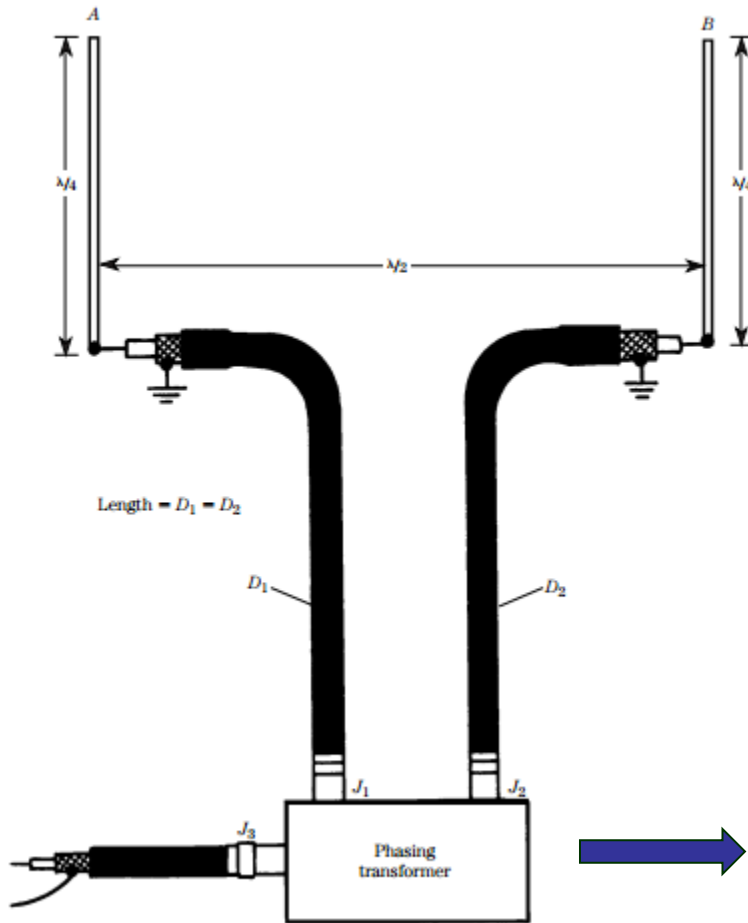


-  **PENDAHULUAN** 
-  **KONSEP DASAR SUSUNAN ANTENA** 
-  **MACAM-MACAM SUSUNAN ANTENA** 
-  **SISTEM PENCATUAN SUSUNAN ANTENA** 
- 
- 
- 

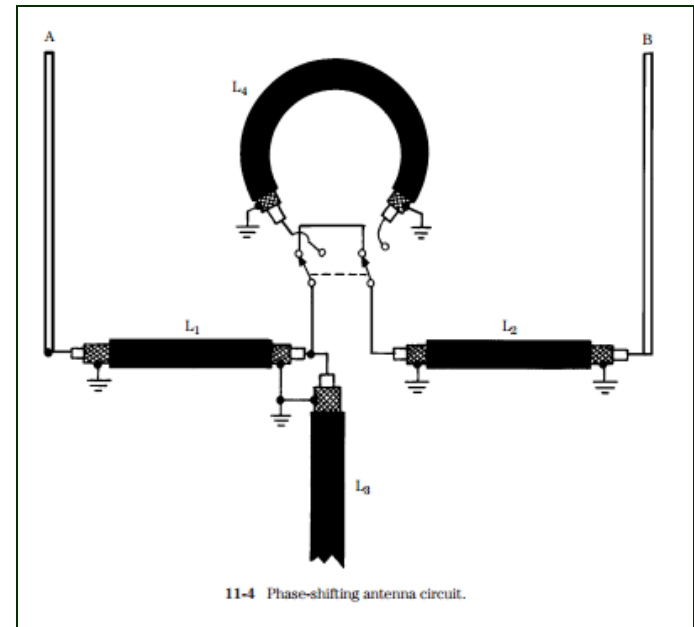
# Sistem Pencatuan susunan Antena



# Sistem Pencatuan susunan Antena



11-3B Connection to antennas.



11-4 Phase-shifting antenna circuit.

# Sistem Pencatuan susunan Antena

## Network Feed

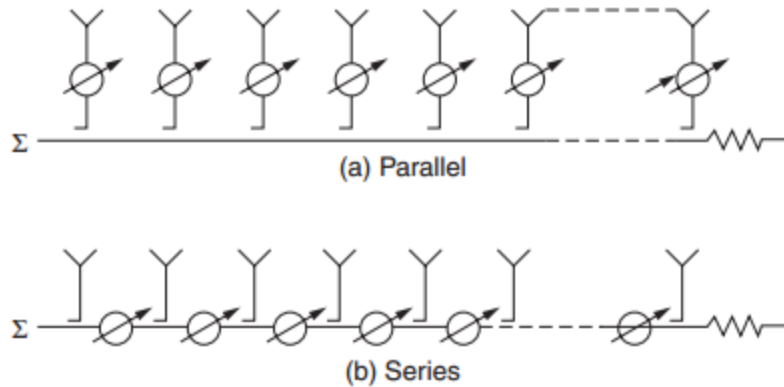


FIGURE 20-18 End-fed series feeds

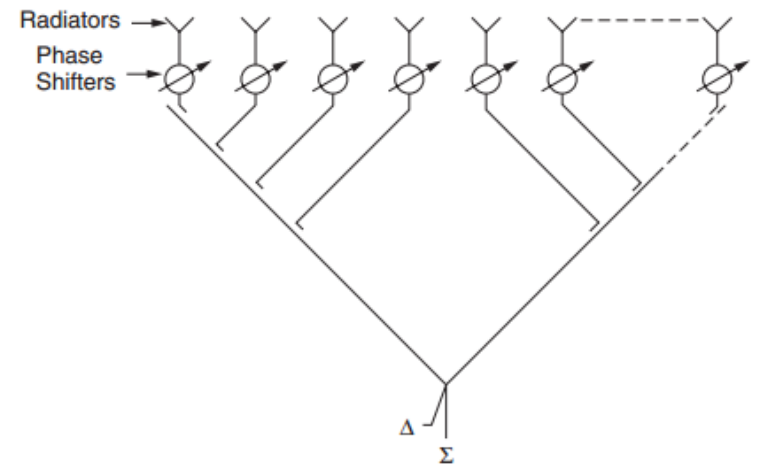
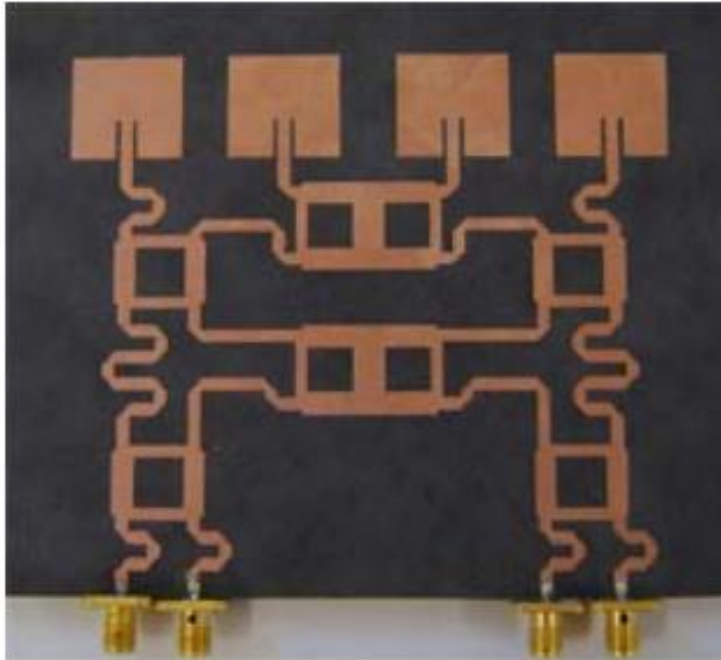


FIGURE 20-20 Equal-path length feed

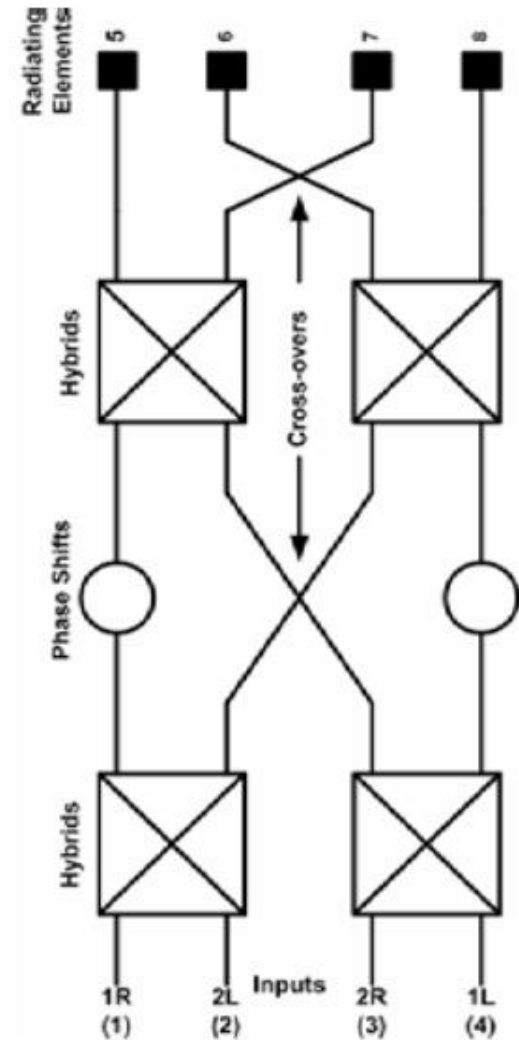


# Sistem Pencatuan susunan Antena

## Multiple beam Feed : Butler Matrix

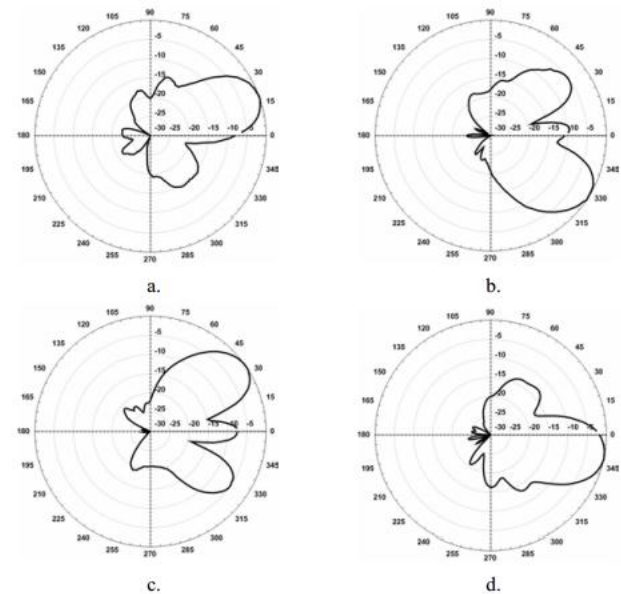
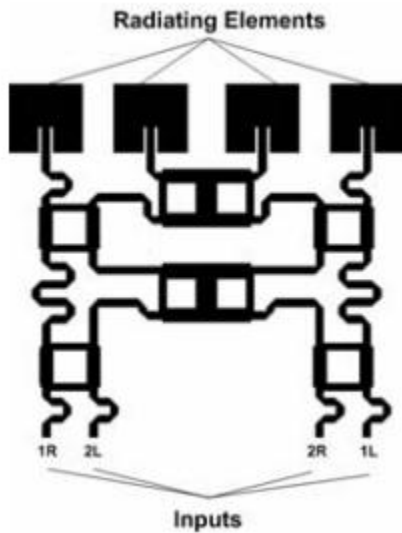


- Terdiri dari :
- Directional couplers
  - crossovers
  - phase shifters



# Sistem Pencatuan susunan Antena

## Multiple beam Feed : Butler Matrix



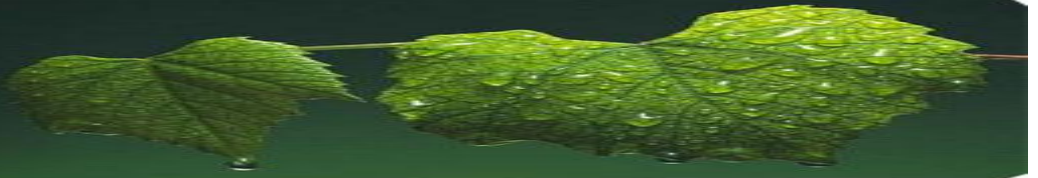
4. Measured beam patterns at 5.25 GHz when a. port 1R is fed, b. port 2L is fed, c. port 2R is fed, and d. port 1L is fed.

Magnitudes and phase shifts at the inputs and outputs of Butler matrix

Port	1R	2L	2R	1L	5	6	7	8
Mag	1	0	0	0	0.524	0.506	0.472	0.480
Phase	0	0	0	0	129.4	90.83	47.98	-1.45
Mag	0	1	0	0	0.481	0.496	0.507	0.497
Phase	0	0	0	0	44.94	175.3	-54.4	88.75
Mag	0	0	1	0	0.497	0.507	0.496	0.481
Phase	0	0	0	0	88.75	-54.4	175.3	44.94
Mag	0	0	0	1	0.480	0.472	0.506	0.524
Phase	0	0	0	0	-1.45	47.98	90.83	129.4

**Sumber :**

**Nhi T. Pham, Gye-An Lee, and Franco De Flaviis**  
**“Microstrip Antenna Array with Beamforming**  
**Network for WLAN Applications”**



Questions???





Thank You !

